



## Adaptation to temporal structure

[Link to publication record in Manchester Research Explorer](#)

### Citation for published version (APA):

Schwartz, M. (2012). *Adaptation to temporal structure*. [Doctoral Thesis, Max Planck Institute for Human Cognitive and Brain Sciences]. Max Planck Institute for Human Cognitive and Brain Sciences.

### Citing this paper

Please note that where the full-text provided on Manchester Research Explorer is the Author Accepted Manuscript or Proof version this may differ from the final Published version. If citing, it is advised that you check and use the publisher's definitive version.

### General rights

Copyright and moral rights for the publications made accessible in the Research Explorer are retained by the authors and/or other copyright owners and it is a condition of accessing publications that users recognise and abide by the legal requirements associated with these rights.

### Takedown policy

If you believe that this document breaches copyright please refer to the University of Manchester's Takedown Procedures [<http://man.ac.uk/04Y6Bo>] or contact [uml.scholarlycommunications@manchester.ac.uk](mailto:uml.scholarlycommunications@manchester.ac.uk) providing relevant details, so we can investigate your claim.



---

## **Adaptation to temporal structure**

---

Impressum

Max Planck Institute for Human Cognitive and Brain Sciences, 2012



Diese Arbeit ist unter folgender Creative Commons-Lizenz lizenziert:  
<http://creativecommons.org/licenses/by-nc/3.0>

Druck: Sächsisches Druck- und Verlagshaus Direct World, Dresden  
Titelbild: <http://de.wikipedia.org/wiki/Datei:Ouroboros1.png>

ISBN 978-3-941504-22-6

# **Adaptation to temporal structure**

Der Humanwissenschaftlichen Fakultät  
der Universität Potsdam  
eingereichte

## **DISSERTATION**

Zur Erlangung des akademischen Grades  
doctor philosophiae  
Dr. phil.

vorgelegt  
von Michael Schwartze, M.A.  
geboren am 07. April 1980 in Lippstadt



## **Danksagung**

Viele haben dazu beigetragen, dass diese Arbeit entstehen konnte. Ihnen möchte ich an dieser Stelle meinen aufrichtigen Dank dafür aussprechen.

Am Max-Planck Institut für Kognitions- und Neurowissenschaften in Leipzig wurde eine ganz besondere Umgebung geschaffen, welche sowohl den notwendigen Freiraum lässt Gedanken zu entwickeln, als auch die faszinierende Möglichkeit bietet das Denken sichtbar zu machen. Ich möchte daher zunächst Prof. Dr. Angela D. Friederici und Prof. Dr. Sonja A. Kotz dafür danken, dass sie mir diese Umgebung zugänglich gemacht haben. Prof. Dr. Kotz möchte ich im Besonderen für die vertrauensvolle Betreuung danken. Sie hat es immer verstanden die Attribute menschlich-fürsorglich und fachlich-fordernd in sich zu vereinen. Diese gelungene Kombination habe ich als ausgesprochen angenehm empfunden.

Daneben möchte ich mich bei einer ganzen Reihe von Freunden und Kollegen bedanken, allen voran bei denjenigen aus meinem ersten Büro, Dr. Anna S. Hasting, Dr. Philipp Kanske und besonders Kathrin Rothermich, die mir nicht nur den Anfang leicht gemacht haben, sondern mir in Gesprächen auch immer wieder neue Anregungen gegeben haben und von denen ich sehr viel gelernt habe. Gleiches gilt für Dr. Maren Schmidt-Kassow, deren Blick auf die Dinge immer wieder bereichernd für die eigene Arbeit ist. Daneben gehört auch Sebastian Wahnelt zu dem Kreis, in dem viele der grundlegenden Ideen entstanden sind. Darüber hinaus bin ich den vielen Kolleginnen (und den wenigen Kollegen) aus der „SOKO“ Gruppe für die hilfreiche Kritik und die anregenden Diskussionen über ihre und über die eigene Arbeit dankbar. Ebenso hat mich Dr. Peter E. Keller bei der Durchführung der Verhaltensexperimente mit Rat und Tat unterstützt. Während der gesamten Zeit hat mir Anika Stockert immer wieder mit anatomischer und medizinischer Expertise ausgeholfen. Cornelia Schmidt, Heike Böthel und Ina Koch haben mich bei der Datenerhebung unterstützt. Kerstin Flake und Andrea Gast-Sandmann haben mir geholfen Ergebnisse grafisch aufzubereiten.

Zudem möchte ich meiner Familie danken, die mich immer darin bestärkt hat den Weg in die eingeschlagene Richtung zu gehen. Abschließend gilt mein ganz besonderer Dank meiner Frau Wiebke, ihrer Liebe, ihrem Verständnis und ihrer Unterstützung, sowie unserem Sohn Johannes, der gerade beginnt sich mit dem Rhythmus dieser Welt vertraut zu machen während diese Zeilen entstehen. Ihr seid meine beste Zeit.



## Contents

<b>I. Introduction</b> .....	1
<b>II. Theoretical Background</b> .....	7
<b>1 Adaptation to temporal structure</b>	
<b>1. Predictive adaptation to patterned temporal structure</b> .....	9
<b>2. Temporal processing</b> .....	14
2.1 Short-range versus longer range temporal processing .....	16
2.2 Event-based versus interval-based temporal processing .....	21
2.3 Automatic versus attention-dependent temporal processing .....	23
<b>2 A temporal processing network</b>	
<b>3. Core components of a dedicated integrative temporal processing network</b> ....	29
3.1 From the earliest stages of auditory processing to the cerebellum .....	32
3.2 Towards the thalamus, and from the thalamus to the cortex .....	35
3.3 From frontal cortices to the basal ganglia – and back .....	40
3.4 Some missing components .....	44
<b>III. Empirical Part</b> .....	47
<b>4. Empirical part – overview</b> .....	49



**3 Article I**

**5. The impact of basal ganglia lesions on sensorimotor synchronization, spontaneous motor tempo, and the detection of tempo changes** ..... 51

1. Introduction<sup>1</sup> ..... 55

2. Materials and Methods ..... 58

    2.1 Participants ..... 58

    2.2 Spontaneous motor tempo task ..... 59

    2.3 Sensorimotor synchronization task ..... 59

3. Results ..... 61

    3.1 Spontaneous motor tempo ..... 61

    3.2 Adaptive timing task ..... 63

    3.3 Detection task ..... 68

4. Discussion ..... 70

5. References ..... 73

**4 Article II**

**6. Temporal regularity effects on pre-attentive and attentive processing of deviance** ..... 77

1. Introduction ..... 81

2. Materials and Methods ..... 84

    2.1 Participants ..... 84

    2.2 Stimulus presentation, EEG recording, and ERP analysis ..... 84

    2.3 Tasks ..... 87

3. Results ..... 87

    3.1 Pre-attentive session ..... 87

    3.2 Attentive session ..... 89

4. Discussion ..... 91

5. References ..... 94

---

<sup>1</sup> Original section numbering maintained within articles.

**5 Article III**

**7. Functional dissociation of pre-SMA and SMA-proper in temporal processing .. 99**

1. Introduction ..... 103

2. Materials and Methods ..... 105

3. Results ..... 112

    3.1 Primary contrast: Sensory versus sensorimotor temporal processing ..... 112

    3.2 Secondary contrast: Sequential versus non-sequential temporal processing 114

    3.3 Secondary contrast: Explicit versus non-explicit temporal processing ..... 114

    3.4 Secondary contrast: Subsecond versus (mixed-) suprasedond temporal processing ..... 115

    3.5 Post-hoc contrasts ..... 115

4. Discussion ..... 117

5. References ..... 120

**IV. Conclusions and future directions ..... 129**

**V. Bibliography ..... 137**

**List of Figures ..... 155**

**List of Tables ..... 157**

**List of Abbreviations ..... 158**



## **I. Introduction**



*„ta panta rhei“*

(Heraclitus, Simplicius)

All changes in the state of an individual and in the environment generate events which can be characterized in terms of their formal and temporal structure. As a consequence, individuals have to perform some form of continuous adaptation not only to formal but also to temporal structure in order to successfully navigate through, and interact with, an ever-changing environment. Navigation requires adjusting the individual point of reference according to some external frame of reference. For this purpose the individual has to acquire some reasonably precise internal representation of the formal and temporal structure of its environment. Internal representations of external structure arise from sensations. Different senses deal with different aspects of formal structure, e.g. color or taste. However, it is a matter of debate whether one may indeed speak of a “sense of time” that is involved in generating an internal representation of temporal structure. What makes time special? It appears to be ubiquitous, but the apparent passage of time, i.e. the strong and intuitively appealing impression of time that flows from the future into the present and into the past constitutes scant evidence regarding the existence of time. This becomes even more evident if one considers that the flow of time depends entirely on the awareness of change (James, 1890). Hence, it is not surprising that the adaptation to temporal structure does not depend upon any abstract notion of time. Time may rather conform to a manifestation that results from the need to exchange information with the non-static environment in order to stay geared to the course of events in this environment (Michon, 1985). In other words, time constitutes an emergent quality of the individual’s adaptation to the temporal structure of the environment. It is a unique experience, but an experience nonetheless (Fraisse, 1992). However, just as time implies individual experience, individual experience implies some physiological foundation. Thus, the question arises as to what physiological, and more specifically, what neural mechanisms give rise to the experience of time? And furthermore, what neural mechanisms engage in the adaptation of the individual to temporal structure?

While the formal structure of events is manifold, and may be as rich and expressive as, for example, in communication or in the fine arts, temporal structure varies widely, but remains one-dimensional nonetheless. The whole experience of time can hence be described sufficiently

in terms of the concepts of duration and succession, impressions which themselves arise from the continuous interplay of persistence and change (Gibson, 1975; Fraisse, 1984). However, despite this putative simplicity, the notion and the nature of time have been, and still remain, controversial in philosophy and the natural sciences alike.

Yet, what causes such enduring fascination with time? Part of an answer to this question is the fact that in the face of numerous theories about time, which span definitions within the spectrum from non-existent and nothing but a measure of temporally marked events (Antiphon; Dunn, 1996), via absolute to relative, it is challenging to bridge the gap between concepts of abstract time and individual experience. Everybody has a more or less clear-cut idea about time, but time is just as well “not a thing that, like an apple, may be perceived” (Woodrow, 1951, p. 1235; Pöppel, 1978). Time appears to have no physical reality that is accessible to the senses (Fraisse, 1992). Hence, the notion of time, while easily conceived, is immensely difficult to communicate. The seminal “Confessiones” by Augustine of Hippo (397/389 AD) contain an early, and probably the most famous quote that illustrates this discrepancy. He notes: “if no one asks me, I know what it is. If I wish to explain it to him who asks me, I do not know.”

Certainly not a satisfying solution to the problem, the conflict can be seen in light of another of Augustine’s remarks: “It is in you, O mind of mine, that I measure the periods of time”. This sober statement points straight to the crucial role of the individual in any realistic theory of time, or in more contemporary and convenient terms, the neuropsychological dimension of temporal processing and the adaptation to temporal structure. These processes represent the first major focus of the following chapters, which deal with temporal processing, the adaptation to temporal structure, and the neuropsychological underpinnings of these mechanisms, rather than any abstract notion of time that is detached from individual experience. In this context, the psychological component of “time” can thus be defined also in psychological terms as the “conscious experiential product of the processes, which allow the (human) organism to adaptively organize itself so that its behavior remains tuned to the sequential (order) relations in its environment” (Michon, 1985, p. 20). What remains to be specified, is the neural component, i.e. the anchoring of these adaptive psychological mechanisms in the (human) brain.

From its beginnings as a discipline and into the present, the issue of time has been at the heart of experimental psychology (Mach, 1865; Vierordt, 1868; Münsterberg, 1889). While interest in the subject waxed and waned over the last century, the study of “time” in general

generated a vast amount of evidence (for classic reviews see Woodrow, 1951; Fraisse, 1963; Doob, 1971; Pöppel, 1978; Allan, 1979). This allowed Zelkind and Spring (1974) to compile a comprehensive list of as many as 1172 studies dealing with “time”. Nevertheless, with the introduction of the concept of space-time, awareness for the omnipresence and the crucial role of time more or less ceded to physics, with the temporal dimension accusingly being lost to psychology and biology (Jones, 1976). However, interest in the topic flourished again in recent years, probably in good part due to the additional quality of analysis that emerged with the continuous development and increasing refinement of contemporary neuroimaging methods (for recent reviews see Lewis and Miall, 2003; Ivry and Spencer, 2004; Buhusi and Meck, 2005; Koch et al., 2009; Coull et al., 2011). For the first time, neuroimaging provides the opportunity to observe the brain in vivo while it performs both, processing in time and adaptation to temporal structure. Crucially, the respective neuropsychological paradigm allows generating neurofunctional models of the underlying processes as well as complementing earlier work, which ultimately has to withstand the test of physiological plausibility. This neurofunctional perspective on temporal processing and the modeling of its physiological basis represent the second major focus of this work, leading to a discussion of the designated purpose and the potentially optimizing role of the adaptation to temporal structure in the interaction with the environment.





## **II. Theoretical Background**



## **Chapter 1**

# **Adaptation to temporal structure**

## **1. Predictive adaptation to patterned temporal structure**

Adaptation to temporal structure co-determines the production, the organization, and the perception of fundamentals such as locomotion, communication, or reasoning. Depending on the identity and the rate of events in the environment, adaptation to the temporal structure of a single setting, e.g. avoiding an approaching car, may require either reflex-like, subtle, or marked adjustments of behavior. Furthermore, adaptation to temporal structure can be prospective, and represented in anticipatory adjustments of behavior, or retrospective, and represented in reactive adjustments of behavior. From an observational perspective, these adjustments of behavior manifest in the interruption, prolongation, preparation, deceleration, or acceleration of movements, i.e. processes, which eventually afford timely action.

Regarding cognitive behavior, adaptation to temporal structure is most likely part and parcel of processes as diverse as decision-making, planning, memory storage and memory recall, or the control of movement. However, the crucial point put forward here is the fact that if the critical event is located in the future, i.e. if the adjustment is anticipatory, adaptation to temporal structure incorporates a mandatory predictive element. Only seemingly trivial, this predictive element is essential to any efficient adaptation to temporal structure as well as to cognition in general. Situated in an ever-changing environment, the individual strives for optimal adaptation to particular situations (Engel et al., 2001). For this reason, “we continuously prefigure events” (Gibbon and Church, 1990, p. 24). We possess a “proactive” (Bar, 2007), and most likely even a “predictive” brain (Bubic et al., 2010), or at least a brain that operates in a “predictive state” (Ghajar and Ivry, 2009). Moreover, one part of this predictive bias may be the predisposition to spontaneously search for regularity in the temporal structure of sensory input, especially in the auditory domain (Drake and Bertrand, 2003; Winkler et al., 2009).

In terms of conceptual complexity, prediction is comparable to the notion of abstract time. Niels Bohr coined the phrase “prediction is very difficult, especially if it’s about the future”. However, while prediction concerns the future, it does not necessarily pertain to temporal structure, as it applies just as well to formal structure. In other words, it is possible to predict the “what” aspect of future events independent of the “when” aspect of the same events, although both may also converge and influence each other. For example, when approaching a traffic light, it is possible to predict a future change in the color of its signal (“what” aspect) without any specific clue as to when this particular change will occur. This differentiation is also relevant with respect to the underlying neural mechanisms, as, dependent on one’s perspective; “prediction” may literally activate the entire brain (Bubic et al., 2010).

The proposed dissociation of formal and temporal structure could help to address this issue by restricting the discussion to temporal structure, albeit without questioning the relevance of formal structure as well as predictions based on formal structure. However, in those cases in which prediction indeed concerns temporal structure, adaptation to temporal structure provides the intriguing opportunity to influence, and possibly also to optimize, the cognitive processing of formal structure. Moreover, it offers a means to control the processing of formal structure via the systematic manipulation of temporal structure. The latter assumption is based on the notion that the faster and more accurate the prediction, the more efficient the adaptation to temporal structure, and consequently, the bigger the potential cognitive processing advantage. In other words, prior knowledge of the “when” aspect affords facilitated processing of the “what” aspect. Coming back to the above example, while approaching a traffic light with three phases, it is possible to predict the changing to a third phase (“when”) based on the temporal structure of the preceding phases. The “ready-set-go” signal used in sports and the “counting in” in music performance or in other contexts most likely represent other common applications of this fundamental mechanism. The resulting facilitatory effect essentially translates to optimal timing, with timing defined as the ability to align cognition and action with events in a timely manner. Optimal timing in both domains should result in improved adaptation to temporal structure and vice versa. Within this interplay, coherence between cognition and action is probably retained, i.e. in most settings the resolution in temporal processing as well as overall cognitive capacity should measure up with the temporal structure of actions. Only in highly overlearned or automatized processes the performance for both may become asymmetric. For example, neither

the producing individual nor the observer may be able to resolve the temporal structure of individual finger movements in piano performance at fastest tempi. From an evolutionary perspective, one may even speculate that such mutual influence may represent a driving force in the development and refinement of increasingly sophisticated skills in cognition and action.

However, what mechanisms allow an individual to predict the temporal locus of future events? One option is to adopt some stable, quasi periodic, external reference against which temporal structure can be judged in order to align actions with events, be it the phases of the moon, the alternations of darkness and light, which constitute a day, or the radiation of the caesium atom,<sup>2</sup> which defines the second. While the former examples are certainly appropriate to align cultural events or cycles of sleep and wakefulness, the latter is necessary to obtain the precise temporal measurements of a present-day atomic clock. Yet, just as abstract time is not a premise for the experience of temporal structure; artificial clocks are not a premise for the generation of predictions about temporal structure. Without doubt, individuals are inherently capable to generate predictions on the basis of what they perceive. Hence, one may modify the above question into: what *neuropsychological* mechanisms allow an individual to predict the future course of events?

A way to achieve temporal prediction without relying on technical artifacts would be inference on the basis of knowledge about the laws of physics, about causality, about probability, as well as associations, which can all be used to make predictions concerning future events. However, these forms of acquired knowledge are not intrinsically temporal and therefore do not necessarily allow for temporally specific predictions and may hence rather pertain to formal predictions. Yet, they are not the only way to generate predictions. Another, probably less obvious possibility arises from the mere exposure of the individual to, and the processing of, temporal structure. The specific arrangement of events can be intrinsically predictive if some regularity in the temporal structure of past events is conceived as continuous and thus predictive with respect to future events. Regularity in temporal structure may correlate with physical measures but may also vary, up to a degree which is still perceived as regular. Predictions on this basis can be either explicit, i.e. generated on the basis of conscious cognitive processes, or implicit, i.e. generated on the basis of physiological properties of the organism. In any case, via

---

<sup>2</sup> According to the English version of the International System of Units (SI), a second is defined as the duration of 9.192.631.770 periods of the radiation corresponding to the transition between the two hyperfine levels of the ground state of the caesium 133 atom at rest at a temperature of 0 K.

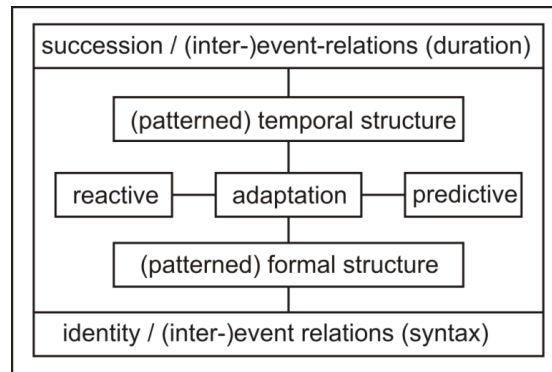
internalization, or induction of regularity in temporal structure the organism becomes capable of performing an “adaptation to change by anticipation” (Fraisse, 1963, p. 18). Conceptually, this process can be similar for short-term and long-term, microscopic and macroscopic temporal regularity, i.e. temporal structure that consists of few or many successive events, or evolves across durations spanning milliseconds or years. Crucially, perceived temporal regularity and temporal predictions are vital to optimal adaptation to temporal structure.

Regularity in temporal structure can be described in terms of “rhythm”. Rhythmic activity and interactions between different rhythms are a fundamental feature of life (Glass, 2001; Jones and Boltz, 1989), culminating in conceptions of rhythm as a life-defining quality, “je rythme donc je suis” (Jousse, 1974). However, whatever difficulties apply to prediction, or the notion of abstract time, apply also to any definition of rhythm. Intuitively, the concept of rhythm is somewhat linked to temporal regularity, or at least to events that (re-)occur in a temporally predictable fashion. The changing of the seasons, of night and day, the tides, or the ticking of a clock all conform to this commonly accepted notion of rhythm. Yet, this perspective on rhythm is too narrow with respect to psychology. Moreover, it is one of two fundamental “misconceptions”, with the other being the notion of *strict* temporal regularities in rhythm (Martin, 1972).

In psychology, the term “rhythm” describes a much broader set of phenomena. It refers to all serial stimuli that are perceived as serial groups of stimuli (Woodrow, 1951). Thus, in the psychological context, grouping, not temporal regularity is the primary criterion for defining rhythm. Consequently, “a rhythm need not be temporally regular or give rise to the perception of temporal regularity. Any temporal pattern of events or acts, even at a random pattern, constitutes a rhythm, as long as the temporal intervals are not too long to prevent the formation of perceptual groups” (Repp, 2000; p. 235). Rhythm is hence not some aspect of formal or temporal structure per se; it is conceived as a perceptual phenomenon. Like time, it is a category of human experience (You, 1994).

However, each and every sequence, i.e. temporally separate events that are conceived as related in some aspect, intrinsically fulfills this criterion. Both formal and temporal structure may give rise to the perception of rhythm, either separate or in combination. As Fraisse (1982, p. 150) notes: “there is rhythm when we can predict on the basis of what is perceived, or, in other words, when we can anticipate what will follow.” In support of this view one may add that there is

rhythm when we can predict when an event will follow. If a sequence is conceived as containing any kind of temporal regularity, this information is probably used by the organism to not only perform reactive, but also proactive adaptation to temporal structure (Fig. 1).



**Fig. 1.** Adaptation to formal and temporal structure. The experience of temporal structure arises from the presence (succession) or absence (duration) of changes that generate events and inter-event relations. The experience of formal structure pertains to the identity and the rule-based combination (syntax) of events and inter-event relations. Regularity in either dimension, i.e. a pattern, allows generating predictions concerning the temporal locus and/or the identity of future events. Identification of a pattern may involve different mechanisms for temporal and formal processing, including the evaluation of past events and inter-event relations. While such evaluation is a prerequisite for reactive adaptation, it may also lead to predictive adaptation. Importantly, adaptation to formal and temporal structure may recruit different neuropsychological bases but contribute to the same goal, i.e. optimized behavior in both perception and production.

Thus, while formal and temporal structure may be independent of each other in this regard, some persistence in either characteristic is still required, i.e. expectancies concerning future events in a sequence based on past events are inherent to the concept of rhythm (Martin, 1972). This latter aspect proves “rhythm” a specific form of a “pattern”. Zeki et al. (2008) define a pattern “as an arrangement or sequence that follows, or is reducible to, some rule or principle, and is characterized by some regularity in the relations among its constituents. This contrasts with arrangements that are irregular, and in which, consequently, no rule or principle can be discerned. The capacity to detect the presence or absence of regularity allows us to simplify or to reduce sets of observations to their underlying rules and laws.” At the most basic level, patterns in the



environment consist of changes in energy (Jones 1976; 1985). Regularity in the formal structure of events conveys patterns *in* time, while regularity in their temporal structure conveys patterns *of* time (Handel, 1974). However, in order to detect the presence or absence of regularity, and to generate temporally precise predictions, the impression of regularity has to arise from an internal representation of temporal structure. This is where some dedicated temporal processing system may be required.

## **2. Temporal processing**

Any naturalistic environment is neither entirely static nor entirely chaotic, and while continuously changing, the environment is neither the same nor completely different after some event occurs (Gibson, 1975). Early on, the interplay of “old objects”, and the incoming of “new objects” has been discussed in relation to memory and expectation, as well as the retrospective and prospective “sense of time” (James, 1890). While probably not as numerous as theories about abstract time, several partly overlapping and partly exclusive neuropsychological approaches to this “sense of time” emerged with the advent and the improvement of non-invasive neuroimaging methods such as electroencephalography (EEG), positron emission tomography (PET), magnetencephalography (MEG), or functional magnetic resonance imaging (fMRI; Meck and Malapani, 2004). Starting with EEG, these neuroimaging methods allow to complement existing theories, based for example on chemical, behavioral, or patient work, as well as to directly address the neuropsychological basis of temporal processing (Goody, 1958; Surwillo, 1966; Jueptner et al., 1995; Rao et al., 1997). Seminal models which take this aspect into consideration have been formulated in the latter half of the 20<sup>th</sup> century, including the pacemaker-accumulator model by Treisman (1963; Treisman et al., 1994) and the scalar expectancy theory proposed by Gibbon et al. (1984; Gibbon et al., 1997). Most important, however, by using these neuroimaging methods, it became possible to not only consider the individual as a factor in theories of time, but to observe the individual experience of temporal structure, i.e. to investigate the physiological basis of temporal processing experimentally. Thereby, the more or less abstract concept of the “internal clock” that is commonly used in

reference to this physiological component of temporal processing has lost much of its metaphorical meaning (Wearden, 2001).

However, in order to unravel the interplay of such a physiological component and an individual experience in the adaptation to temporal structure, it is necessary to further specify what exactly is meant by the terms “temporal processing” and “temporal structure”. This is especially true for any approach to temporal processing that builds on the processing of events, rather than abstract time. It is also critical in order to dissociate the role of different brain structures. For example, Fuster (1995) attributes a function related to the “processing in time”, i.e. time in relation to experience and behavior, rather than the “processing of time” to the prefrontal cortex. While this dissociation resembles the difference between patterns in time and patterns of time, it does not preclude a third alternative. This alternative view is promoted in the following. The term “temporal processing” will be used with a connotation that is neither restricted to “processing in time” nor to the “processing of time”. In this context, “temporal processing” refers to the neuropsychological mechanisms that underlie the encoding and decoding of temporal structure, as well as the evaluation of the respective information. These mechanisms imply succession and duration on their own, thereby generating temporal structure, but they are also considered to deal explicitly with temporal structure and to generate a direct internal representation of it. In turn, the term “temporal structure” will refer exclusively to the organization of events and inter-event relations in terms of duration and succession, i.e. temporal structure is considered independent of formal structure in this respect. Such dissociation of the temporal and the formal aspect of events may seem ad-hoc at first glance. However, it owes to the notion that temporal structure across modalities provides but one kind of domain-independent information. This information, by its own virtue, may subsequently be used in complex cognitive operations, e.g. retrospective comparisons of durations, temporizing of successive actions, recognition of temporal patterns, as well as temporal predictions. These concrete operations may in turn be responsible for the persistent notion of abstract time as a likewise concrete entity.

The dissociation of formal and temporal structure leads to probably the most fundamental question with respect to temporal processing. This question concerns its exclusiveness, i.e. whether temporal processing is intrinsic to context- or sensory-specific processes, or whether it is performed by some dedicated context-independent temporal processing system (Ivry and Schlerf, 2008; Coull et al., 2011). In other words, do neuropsychological mechanisms actually

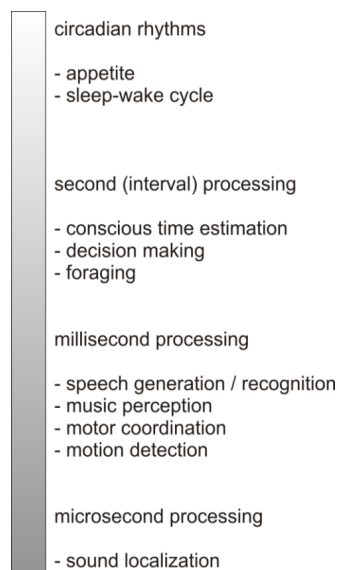
discriminate between formal and temporal structure? Even if one accepts this perspective, as it is the case for the above definitions of temporal processing and temporal structure, it remains an open issue whether one, several, or a distributed system engages in temporal processing (Ivry and Spencer, 2004; Ivry and Schlerf, 2008).

What neural structures represent candidates for such system? As Fuster (2001) emphasized, all adaptive behavior eventually involves circular processing of information between the organism and its environment. While this does not necessarily imply structural convergence, and even less so structural identity, there is by now compelling evidence, which suggests a role of classical motor areas of the brain not only in the production, but also in the perception of temporal structure. Early on, concepts of temporal processing incorporated speculations about the role of the cerebellum, the thalamus, or the basal ganglia (Gooddy, 1958). More recently, activation of the supplementary motor area (SMA), the cerebellum, and the basal ganglia is considered as one of the most consistent findings with respect to temporal processing (for reviews see Buhusi and Meck, 2005; Macar et al., 2006; Ivry and Schlerf, 2008; Coull et al., 2011). The role of the SMA in this specific context has been linked to invoking a time line against which temporal structure can be aligned and quantified (Coull et al., 2004). This function probably generalizes to the accumulation of a duration that is currently unfolding in time (Coull et al., 2008; Coull et al., 2011). The cerebellum is thought to be involved in automatic temporal processing, whereas the basal ganglia and associated cortico-striato-thalamo-cortical circuits presumably engage in attention-dependent temporal processing (Buhusi and Meck, 2005). Each of these structures probably provides a unique aspect to temporal processing. However, before any functional relation between these individual candidates for a dedicated neural basis of temporal processing can be established, several additional neuropsychological oppositions have to be considered, first and foremost the dissociation of different mechanisms for temporal processing on different timescales.

## **2.1 Short-range versus longer range temporal processing**

Independent of the neuropsychological mechanisms involved, it is evident that humans process temporal structure across several timescales. These timescales comprise at least 10 orders of

magnitude, spanning levels from microseconds to circadian rhythms (Fig. 2; Mauk and Buonomano, 2004; Buhusi and Meck, 2005). However, it is most likely in the range from tens to hundreds of milliseconds, in which temporal processing is most sophisticated, and where it coincides with other complex processes such as speech recognition, motor coordination or music perception, whose temporal structure can be further differentiated (Shamma, 2003; Buonomano, 2007). It is also within the milliseconds range in which the experience of temporal structure emerges, as events start to be perceived as instantaneous or durable, simultaneous or successive (Fraisse, 1984). Temporal processing in the subsecond range should hence be dissociated from the suprasedond range in which memory intervenes with temporal processing (Fraisse, 1984). Accordingly, temporal processing in the milliseconds range has been distinguished from both, circadian rhythms on the one hand and interval processing in the seconds-to-minutes-to-hours range on the other hand (Buhusi and Meck, 2005).

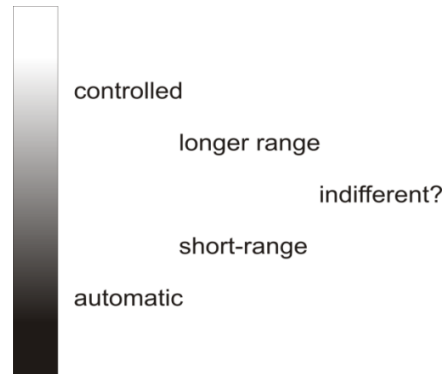


**Fig. 2.** Temporal processing on different timescales. Circadian rhythms correspond roughly to successive 24-hour light-dark cycles, while interaural delays on the order of tens to hundreds of microseconds provide cues for the spatial localization of sound. In between, short-range millisecond processing has been dissociated from longer-range processing of intervals lasting seconds, minutes, or hours (Mauk and Buonomano, 2004; Buhusi and Meck, 2005; Buonomano, 2007).

However, the dissociation of subsecond and suprasedond temporal processing is but one of several neurofunctional dichotomies with others concerning, for example, issues of hemispheric lateralization or the opposition of perception and production (Coull and Nobre, 2008). Furthermore, the proposed boundary line at 1 s itself is most likely just an approximation of a more basic neuropsychological dissociation, owing to our familiarity with this specific unit of temporal measurement. Indeed, other values have been proposed. For example, Michon (1985) suggests that temporal processing below 500 ms is fast, parallel, and not accessible to cognitive control, whereas processing in between 500 ms and 20 s constitutes a variable temporal window, an “interface with reality” (Michon, 1985, p. 40), that is framed by the bounds of working memory. Neuropharmacological work supports the dissociation of different mechanisms, with processing of intervals shorter than 500 ms considered automatic, and outside of cognitive control, whereas intervals in the range of seconds engage working memory (Rammsayer, 1999). Otherwise concurring work suggests retaining a value closer to 1 s (Lewis and Miall, 2006). These selective examples illustrate a considerable lack of clarification regarding this issue. One way to address the problem would be to assume not categorical, but partially overlapping ranges for short-range and longer-range temporal processing mechanisms. Such overlap of intrinsic mechanisms that are responsible for perception, on the one hand, and mechanisms responsible for estimation on the other hand has indeed been suggested for the range between 400 and 800 ms (Karmarkar and Buonomano, 2007). The proposed mechanism for intrinsic temporal processing, i.e. state dependent networks, may, however, be limited to intervals shorter than 300 ms (Spencer et al., 2009). Correspondingly, in dedicated temporal processing models, very short intervals are probably encoded directly, thereby blurring the distinction between intrinsic and dedicated temporal processing in this specific range, whereas longer intervals engage attention and working memory (Ivry and Schlerf, 2008). A slightly different, though compatible solution would be to assume parallel engagement of short-range and longer-range mechanisms (Buhusi and Meck, 2005; Coull et al., 2011), either isolated from each other, functionally connected (O’Reilly et al., 2008), or combined in an integrative dedicated subcortico-cortical temporal processing network (Kotz and Schwartz, 2010).

Apart from the fundamental dissociation of short-range and longer-range temporal processing, several landmarks have been identified for both, the sensory- and the sensorimotor

domain, even within the subsecond range. At the lowest level, interaural differences in the microsecond range provide cues for sound localization. Further into the milliseconds range and beyond the thresholds for temporal fusion and temporal order (Pöppel, 1978); accurate discrimination and sensorimotor synchronization, i.e. the temporal coordination of an action with predictable external events, become possible starting with intervals of about 100 ms (London, 2002; Repp, 2005). Sensorimotor synchronization is most regular for intervals between 400 and 800 ms (Fraisse, 1982). Optimal tempo sensitivity is obtained with intervals from 300 to 900 ms (Drake and Botte, 1993), while intervals between 600 and 700 ms afford optimal pulse sensation (Parncutt, 1994). An interval between 500 and 700 ms, i.e. approximately 600 ms, does not only correspond to the most frequent assessment of the “indifference interval”, i.e. an interval that is neither under- nor overestimated (Vierordt, 1868; Woodrow, 1951), it is also most representative for measures of an unpaced spontaneous, “personal”, or “mental” tempo (Fraisse, 1982). Such spontaneous motor tempo develops across the life-span and it correlates with measures of preferred perceptual tempo, especially in adults, while children may also prefer faster and probably more “attention-getting” tempi (Drake et al., 2000; Baruch et al., 2004; McAuley et al., 2006). Although by no means exhaustive, the above examples illustrate that temporal processing in the milliseconds range is a rather complex phenomenon, probably engages different mechanisms, and is possibly most stable for intervals of about 600 ms. Regarding the latter, one may speculate that this special status is related to the convergence of different mechanisms around this specific tempo, i.e. an interval of 600 ms may fall within the processing range of both automatic and cognitively controlled temporal processing mechanisms (Fig. 3).



**Fig. 3.** Temporal processing in the milliseconds range. Short-range temporal processing up to several hundreds of milliseconds is considered automatic, while longer range processing from several hundreds of milliseconds onwards may fall under cognitive control. Processing in an intermediate range may be accurately performed by both mechanisms, either separately or in parallel. The special status of intervals in the intermediate range may be either a cause or a consequence of this overlap. In the former case, perception and production of intervals around 600 ms may shape the neural basis of temporal processing. In the latter case, the neural basis of temporal processing may shape the perception and production of intervals around 600 ms. Crucially, both mechanisms may lead to optimal temporal processing in this particular range.

Regarding the neural mechanisms involved in short-range and longer range temporal processing, it has been proposed that the cerebellum engages in the former, while the basal ganglia and associated cortico-striato-thalamo-cortical circuits are involved in the latter (Ivry, 1996; Buhusi and Meck, 2005). Neuroimaging studies which explicitly investigate this issue provide partial support for this view but report also considerable structural overlap between structures involved in short-range and longer-range processing (Lewis and Miall, 2003a; Jahanshahi et al., 2006). However, in addition, repetitive transcranial magnetic stimulation (rTMS) has been used to address this dissociation. If rTMS is applied to structures that are associated with either process, Lee et al. (2007) showed that rTMS over the right lateral or medial cerebellum interfered with performance in a subsequent temporal bisection task in the subsecond range (400-800 ms), but not in the suprasedond range (1000-2000 ms), while Jones et al. (2004) demonstrated that rTMS over the right dorso-lateral prefrontal cortex (DLPFC) produces a selective underestimation of long (2000 ms) intervals, while it has no effect on the estimation of short (500 ms) intervals. Likewise, Koch et al. (2007) report rTMS interference within the subsecond (400-600 ms) range

if it is applied over the right or the left lateral cerebellum and within the suprasecond (1600-2400 ms) range if it is applied over the right DLPFC. Based on these observations, the role of the cerebellum can be linked to the quick estimation of brief intervals and the processing of temporal structure, which consists of precise salient events whereas the basal ganglia and its thalamo-cortical connections presumably play a role in the processing of suprasecond intervals and in association with other cognitive functions (Koch et al., 2009). However, most likely several additional parameters have to be considered. This leads to another functional dichotomy, which concerns the dissociation of event-based and interval-based temporal processing.

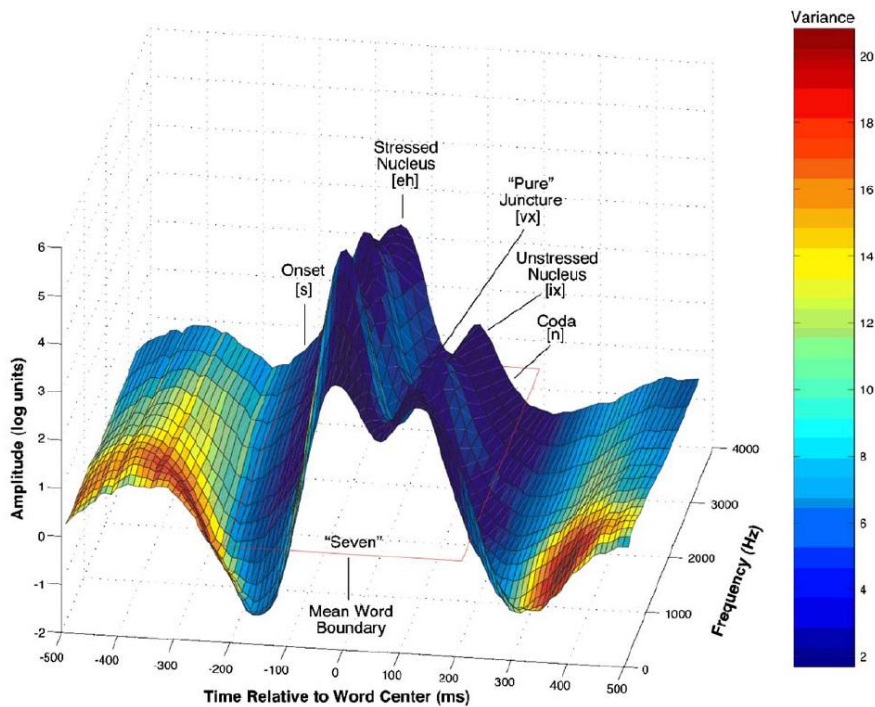
## **2.2 Event-based versus interval-based temporal processing**

In addition to the proposed difference between short-range and longer-range temporal processing, there is evidence for another dissociation that is based on task characteristics. Spencer et al. (2003) suggest that the temporal control of discontinuous movements, e.g. finger tapping, as opposed to continuous movements, e.g. circle drawing, engages different neural systems. While discontinuities like onsets or offsets and also salient features instantiate an event structure, continuous movements lack this event structure (Ivry and Spencer, 2004). In the latter case, temporal structure is hypothesized to be an emergent property of other mechanisms such as motor control (Schlerf et al., 2007). Like short-range temporal processing, event-based temporal processing is assumed to involve the cerebellum as patients with cerebellar lesions are selectively impaired if the experimental task incorporates event-based temporal structure (Spencer et al., 2003). Complementary, the cortico-striato-thalamo-cortical system is assumed to be engaged in continuous-event or interval-based temporal processing, coinciding with its role in longer-range temporal processing (Buhusi and Meck, 2005).

Crucially, the concept of event-based processing is extendable beyond the motor domain. Across different contexts, the role of the cerebellum may relate to the precise encoding of the temporal relationship between successive events (Ivry and Spencer, 2004). Moreover, event-based temporal processing is not necessarily restricted to discrete information. If salient features of a signal embody an event-structure, it is important to specify what formal features convey changes that generate events, which in turn give rise to the experience of temporal structure. For



example, regarding speech one may draw upon work that illustrates why parts of a syllable may represent marked events on one timescale while they are embedded in an otherwise “continuous” signal, i.e. events on another timescale (Fig. 4).



**Fig. 4.** Adopted from Greenberg et al. (2003). The original figure legend reads: *An illustration of a spectro-temporal profile (STeP) for a single word, “seven” taken from the OGI Numbers95 corpus. The step is derived from the energy contour across time and frequency associated with many hundreds of instances of “seven” spoken by as many different speakers. The spectrum was partitioned into 15 one-quarter-octave bands distributed between 300 and 3400 Hz (i.e., telephone bandwidth). The duration of each time frame is 10 ms. The amplitude was computed over a 25-ms window in terms of logarithmic (base  $e$ ) units relative to the utterance mean. Each instance of a word was aligned with the other words at its arithmetic center. The mean duration of all instances of “seven” is shown by the red rectangle. The variance associated with the energy contour for each time-frequency cell is shown in greyscale in the figure, but is depicted in colour in the on-line version of this paper. In the on-line version a “cool” color such as blue, is associated with low variance, while a “hot” color, such as red, is associated with higher variance. The STeP has been labeled with respect to its segmental and syllabic components in order to indicate the relationship between onset, nucleus, coda and realizations within the syllable and their durational properties.*

Sufficiently large and abrupt changes in the energy level of the speech signal may initiate event-based temporal processing, thereby adding a “when” aspect to the “where”, “how”, and “what” streams discussed in speech processing (Scott et al., 2009; Kotz and Schwartze, 2010). In the above example, the stressed nucleus, usually a vowel, may represent an event that is marked by sufficient contrasts in characteristics such as rise-time and sonority. The respective fluctuation in energy reaches a peak during maximum oral aperture, thus labeling accented syllables as “signposts” among other syllables (Greenberg et al., 2003; Greenberg, 2006). If the temporal structure that is conveyed by these events is perceived as regular, one could speak of a perceptual “beat” that occurs near the onset of vowels (Port, 2003). Contrasts in loudness distinguish between one syllable and adjacent syllables, thereby marking the “beat” of speech (Kochanski and Orphanidou, 2008). Moreover, perceived speaking rate slows down as inter-vowel-onset intervals increase (Kato et al., 2003). The special status of the accented syllable and the vocalic nucleus is also reflected at the neuronal level. Neurons in the cochlear nuclei are specifically sensitive to vowel sounds (Rupert et al., 1977) while phonetic dimensions such as the vocal tract opening are represented directly at the level of the auditory nerve (Delgutte and Kiang, 1984).

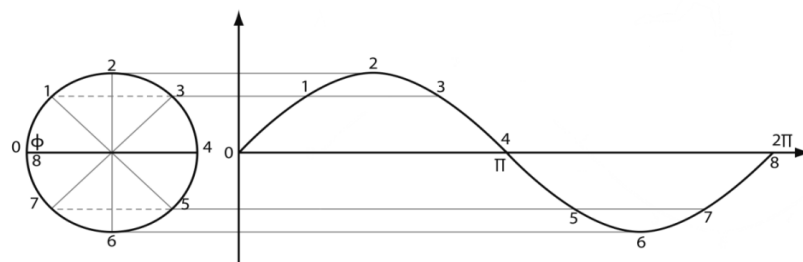
However, the underlying principle of events that are embedded in either discrete or quasi-continuous streams of information is universal and hence applies just as well to speech as it does to music, motion or to temporal structure in any other domain. Hence, comparable to short-range and longer-range temporal processing, parallel engagement of event-based and continuous-event, or interval-based temporal processing mechanisms, is probably the rule rather than an exception.

### **2.3 Automatic versus attention-dependent temporal processing**

The final distinction made in this context is between automatic and attention-dependent temporal processing (Buhusi and Meck, 2005). Attention is a crucial factor in temporal processing. For example, attention to a stimulus prolongs its perceived duration, while less attention results in shorter and more variable perceived durations (for a review see Grondin, 2001). Hence, with respect to the relation of attention and temporal processing, at least two aspects need to be dissociated, the “orienting of attention to time” and the “orienting of attention in time”. The former requires some explicit temporal goal, e.g. established via task instructions and has been

shown to recruit the pre-SMA (Coull et al., 2004). The latter may involve implicit temporal processing (Coull and Nobre, 2008). However, the term “attention-dependent” does not explicitly differ between these categories. In the following, it is used to indicate a state, in which attention is directed towards temporal structure, albeit not necessarily in combination with a specific temporal goal. This state has been related to temporal processing in cortico-striato-thalamo-cortical circuits, thereby adding a further aspect to the proposed roles in longer-range and interval-based temporal processing, whereas automatic temporal processing has been suggested to engage the cerebellum (Buhusi and Meck, 2005). If the cerebellum is considered to be a dedicated short-range temporal processing system, it seems reasonable to assume that it functions independent of attention, i.e. automatic, or at least pre-attentively. However, as for the distinction of temporal processing systems based on temporal range or the opposition of event- and interval-based processing, the conditions under which temporal structure can indeed be perceived automatically need to be further specified (Grondin, 2001).

A conceptually related perspective on attention-dependent temporal processing is provided by the dynamic attending theory (DAT; Jones, 1976; Large and Jones, 1999; Barnes and Jones, 2000). Though not primarily a theory of temporal processing, DAT develops along the interplay of external temporal structure and an internal mechanism, i.e. the allocation of attention in time. DAT considers the allocation of attention as a dynamic, stimulus-driven process. This process is modeled as an internal adaptive oscillation that is capable of entrainment, i.e. locking-into or synchronizing with the temporal structure of external events (Fig. 5).



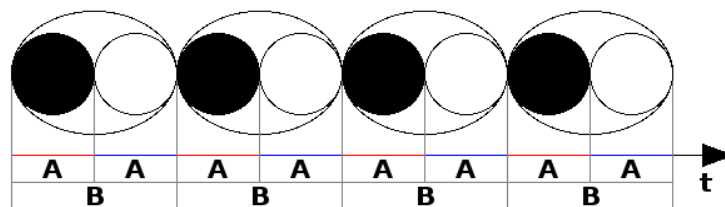
**Fig. 5.** Periodic oscillation. A phase-portrait (left) or a time-series (right) can be used to describe events that repeat with fixed inter-event temporal relations (the period of the oscillation). If an oscillation is periodic, or quasilinear, the phase portrait is a circle. Marked positions in either visualization describe the state of the oscillation at a given fraction of this period (the phase of the oscillation). Different oscillations get synchronized by adjusting their phase and period in order to oscillate with a common frequency.

Thus, synchronization, which can be defined as the adjustment of rhythms of oscillating objects (Pikovsky et al., 2003), provides a means to cope with temporal structure and “to stay geared to the course of events in the environment” (Michon, 1985, p. 46). This perspective rests on two fundamental principles: (1) organisms possess an intrinsic temporal organization manifest in perceptual rhythms, and (2) by means of synchronization, these perceptual rhythms tune to patterns in the environment (Jones, 1976). More specifically, the onsets of events, and probably also other salient events, define a series of nested time periods that attracts perceptual rhythms with similar periods (Jones, 1976). Adaptation to temporal structure via synchronization could be achieved on the basis of adjusting the internal oscillation by means of phase and period correction in response to relative phase discrepancies as a result of variations in temporal structure (McAuley and Miller, 2007).

One important consequence that arises from this conception is the assumption that the rate and the rhythm of events may facilitate the allocation of attention in time, while a loss of the ability to lock into temporal structure may lead to cognitive decline (McAuley et al., 2006). DAT resembles earlier concepts regarding a “wave of attention” (Woodrow, 1951) or the description of attention as “discontinuous and intermittent” that “manifests itself in a wave-like form” (Bolton, 1894, p. 155). This perspective can be summarized in one principle: “no one can possibly attend continuously to an object that does not change” (James, 1890, p. 420; Bolton 1894, p. 155). Likewise, temporal processing has been suggested to proceed in a discontinuous and intermittent fashion (Stroud, 1955; Fraisse, 1984). In other words: “whereas physical time is a continuous variable, psychological time is a discrete variable” (Stroud, 1967, p. 624). Originating from a discussion of the indifference interval and its multiples, James (1890) speculates about some periodic or rhythmic sharpening of the “time-sense”. One may speculate that attention-dependent temporal processing fuses two dynamic processes into one mechanism. Furthermore, the orienting of attention can be considered a change in the state of the individual, which in turn may be considered as an event. Regularity in temporal structure may hence well entail “sharpening” with respect to the allocation of attention, as well as subsequent prospective adaptation to temporal structure. DAT suggests that the attentional focus narrows with regular temporal structure and widens with irregular temporal structure (Jones et al., 2002). Furthermore, as the stimulus-driven synchronization of an internal and an external oscillation generates an internal representation of temporal structure, this mechanism may eventually provide a means to

optimize cognitive processing via adaptation to temporal structure and vice versa. Crucially, by integrating fluctuations of attention with temporal structure DAT provides a unifying framework for attention-dependent temporal processing.

Several attention oscillations in the sense of DAT constitute an “expectancy scheme”, defined as a set of oscillations with the ability to synchronize to different hierarchical levels of temporal structure (Drake et al., 2000). Such schemes, representing the activity of different oscillators, provide a link to larger scale neuronal oscillatory activity and allow for simultaneous tracking of different sources and nested temporal structure (Fig. 6). Even if temporal structure is irregular, a set of oscillations may track the sequence, although periodic expectancies become less precise (McAuley and Jones, 2003). However, it may also afford more efficient sampling of an input, e.g. the tracking of successive syllabic nuclei instead of only stressed ones. Likewise, it can explain how both, the duration of an event and the inter-onset intervals between successive events may be encoded simultaneously. This is critical, since efficient tracking of temporal structure most likely requires encoding the duration of an event, as well as the inter-event temporal relation and the inter-onset temporal relation of successive events.



**Fig. 6.** Two oscillations tracking temporal structure. The temporal structure of periodically occurring events with identical formal structure (black circles) as well as identical durations of the events (red) and inter-event relations (white circles, blue) can be tracked by different oscillations. In the above example, each circle corresponds to the period of an oscillation. One (A) entrains to the stimulus duration and continues to oscillate with the respective period, whereas the other (B) entrains to the inter-onset interval and continues to oscillate with that period.

Inherent to the method, oscillations have also been discussed with respect to EEG recordings. For example, synchronization across different frequency bands has been assumed to reflect different processes, including, for example, a clock-system (Goody, 1958), temporal binding

(Engel et al., 2001), time coupling between rhythmic sensory input and motor output (Will and Berg, 2007), directed attention and maintenance of working memory (Jensen et al., 2007), or attentional selection (Lakatos et al., 2008). Furthermore, on a much smaller scale and in an anatomically concrete manner, neuronal oscillations play a role in the modeling of attention-dependent temporal processing in cortico-striato-thalamo-cortical circuits. The influential striatal beat frequency (SBF) model develops around a set of cortical oscillations that provide input to the basal ganglia as an informational basis to store intervals (Miall, 1989; Matell and Meck, 2004; Buhusi and Meck, 2005). It stands to reason whether these different sets of oscillations, including DAT, stand in any relation to each other, i.e. whether stimulus-driven attending may gate temporal structure into an attention-dependent temporal processing system. Finally, in order to address this issue and to identify additional functional and structural links between different approaches to temporal processing, it deems necessary to integrate several of the characteristics discussed in this chapter into a coherent framework.



## **Chapter 2**

### **A temporal processing network**

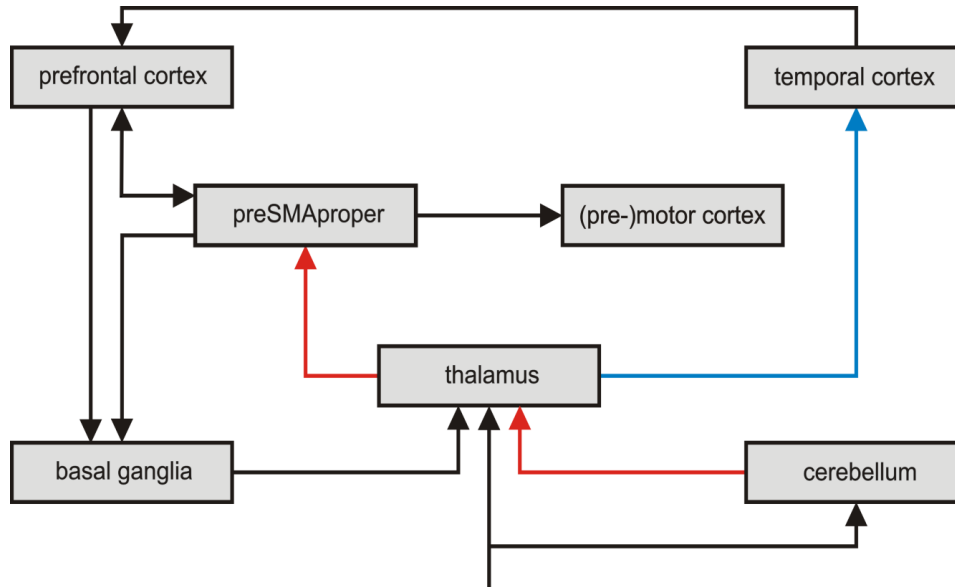
#### **3. Core components of a dedicated integrative temporal processing network**

Despite the dissociation of different temporal processing mechanisms that may work in parallel, it has also been suggested that it is probably necessary to integrate several approaches in order to eventually reveal the neural mechanisms underlying temporal processing (Buhusi and Meck, 2005). Such an integrative approach would have to consider both, functional and structural connections between different, and probably specialized, subcomponents of a larger temporal processing network. Ivry (1996) remarks that the cerebellum and the basal ganglia may form an integrated circuit, with the functional role of these structures yet to be defined. In a similar vein, Meck (2005) suggests that cerebellar and fronto-striatal systems may interact across a range of durations, with fronto-striatal circuits providing the opportunity to rescale durations and to compensate for error differences generated by the cerebellum. However, what structural connections substantiate such speculations?

In order to address this issue it is necessary to assess temporal processing mechanisms from a broad connectionist perspective. Moreover, given that temporal processing recruits classical motor areas in production and perception, it is necessary to answer the key question as to how sensory information reaches these areas in the first place, and furthermore, what processing stages an internal representation of external temporal structure passes on its way there. Considering the flow of information from the sensory periphery to central levels, subcortical stages obviously have to precede cortical processing stages in perceptual temporal processing. In this regard, it seems plausible to start with some further assumptions. Mechanisms operating in the longer range presumably built upon short-range processing. Short-range processing probably depends on very precise internal representations of external temporal structure and should



therefore have access to information provided by early stages of sensory processing. If temporal processing engages a dedicated system, the mechanisms should also be applicable across domains. However, temporal processing is probably most crucial in the auditory domain, as sound essentially represents energy distributed over time. Two of the most sophisticated acoustic signals, music and speech, do not only represent hallmarks of cognitive evolution. At the same time they constitute two of the most demanding activities with respect to motor coordination. Moreover, music can be defined as the art of organizing events in time (Drake and Bertrand, 2003). As a starting point it thus seems justified to approach the neural basis of temporal processing from an auditory perspective and, where necessary, to transfer the specific findings to other domains. These aspects taken into account, it is possible to link the core components that are associated with temporal processing into a dedicated integrative temporal processing network. As indicated, such network needs to include at least the cerebellum, the SMA, the basal ganglia, and the thalamus. As the auditory modality was chosen as an example, it also has to include the temporal cortex. All of these areas are connected to the prefrontal cortex. Furthermore, anatomical data suggest dissociating between the two subareas of the SMA, the more rostral pre-SMA and the more caudal SMA-proper and their specific connections to the cerebellum as well as to prefrontal and motor cortices (Fig. 7).



**Fig. 7.** Core components of a dedicated integrative temporal processing network. Sensory information reaches both thalamus and cerebellum from the earliest stages of sensory processing. In the auditory domain, this may include connections from the cochlea nucleus, where the cochlear nerve terminates to the cerebellum as well as to the inferior colliculus and from there to the thalamus. Via the thalamus, a representation of the input which preserves detailed linear formal and temporal structure (blue) reaches the temporal cortex where it initiates sensory and long-term memory processing. Automatically, the cerebellum conveys an event-based non-linear representation of temporal structure (red) to frontal cortices, most importantly, the pre-SMA. This non-linear representation mirrors salient features of the input, including signal onsets, offsets, as well as sufficiently large or abrupt changes in energy. This event-based representation of temporal structure attracts attention and guides the orienting, as well as the maintenance of attention. Attention is a prerequisite for attention-dependent temporal processing and the encoding and of temporal inter-event relations (intervals) in cortico-striato-thalamo-cortical circuits, which provides the basis of an evaluation of temporal structure, e.g. in order to recognize a pattern. The continuous evaluation of temporal structure necessitates working memory and recruits prefrontal cortex. Integration of temporal structure and memory content provided via fronto-temporal connections affords directing attention to the salient features of the input, whereas pattern recognition affords prospective adaptation to temporal structure.

In production, the decision to initiate action activates the prefrontal cortex. In order to implement this decision and to provide continuous temporal structure to successive actions, the pre-SMA and striato-thalamo-cortical connections act as a “pacemaker” that provides a temporal grid in order to sequence successive actions. Actions are implemented according to this temporal structure, with the cerebellum possibly involved in the short-range, context-dependent fine-tuning of stereotyped action plans. The actual implementation of successive actions then recruits the SMA-proper and its connections to premotor and to primary motor cortices.

We have outlined elsewhere how this temporal processing network may contribute to a specific audio-motor process, namely speech processing (Kotz and Schwartz, 2010). In the following, the network will be discussed from a more general auditory perspective. However, within this discussion, the main focus is on a novel interpretation regarding the role of the cerebellum in auditory temporal processing, as well as on its connections to frontal cortices via the thalamus, rather than the well-known ascending auditory pathway to the temporal cortex or fronto-temporal connections via white matter fiber tracts. This restriction reflects the proposed dissociation of temporal and formal structure, with dedicated temporal processing linked to the former, and the processing of formal structure associated with the latter pathway.

### **3.1 From the earliest stages of auditory processing to the cerebellum**

As early as 1944, Snider and Stowell describe discrete surface potentials with short latencies in the cerebellum of cats in response to click stimulation. They conclude that the cerebellum comprises not only tactile and visual, but also auditory ‘receiving areas’. Correspondingly, an activation-likelihood-estimation meta-analysis identifies several consistently activated regions across the cerebellum, most prominently in the right anterior lateral portion (Petacchi et al., 2005). However, comparably few studies aimed directly at specifying the anatomical and functional implications that result from this observation (Parsons et al., 2009).

By now it is established that the cerebellum, via its connections to several cortical sites, is in the position to participate in motor as well as non-motor processes (Strick et al., 2009). It has been shown that the cerebellar dentate nucleus comprises separate motor and non-motor parts, which project via the thalamus to different cortical areas, including primary motor, prefrontal, and posterior parietal cortex (Dum and Strick, 2003; Taber et al., 2005; Akkal et al., 2007). The signal from the dentate to prefrontal areas is probably as important as its signal to motor areas (Strick et al., 2009). With respect to the proposed role of the cerebellum in short-range, automatic stages of temporal processing, one crucial question is whether the cerebellum receives input from the earliest stages of sensory processing, and more specifically, from early auditory processing. Such connection deems necessary if temporal structure is to be conveyed with

minimal lag and with maximal precision, i.e. without passing through thalamic and/or cortical processing levels, before it reaches the cerebellum.

Anatomical studies in different animal species indeed provide evidence for direct connections to the cerebellum (Aitkin and Boyd, 1975). For example, in rats, auditory information is conveyed faster to the cerebellum than to the cortex (Lorenzo et al., 1977). Snider and Stowell (1944) report negative results after destruction of the bilateral inferior colliculi, however, after tracer injections into cerebellar auditory areas of cats, Huang et al. (1982) observed retrograde labeling of cells in the cochlear nuclei bilaterally, but not in the superior olivary complex or in the inferior colliculus. This finding implies that the cochlear nucleus is structurally connected to the cerebellum. Zhang et al. (1990) report retrograde labeling of the cochlear nucleus and the superior olivary complex in bats after injections into the vermis. Transport of tracers has also been observed in the opposite direction. Injections into the basal turn of the scala media of chinchillas labeled regions of the cochlear nucleus and the cerebellar flocculus, but not of more central auditory nuclei (Morest et al., 1997). Using intracellular recordings in the cerebellar dentate of cats, Xi et al. (1994) obtained responses to click stimulation with latencies as short as 4-14 ms. The authors conclude that a group of dentate neurons should be considered as part of the primary auditory transmission system. Likewise, Wang et al. (1991) identified unit activity in the dentate of cats in response to click stimulation with a latency of 4-6 ms. They interpret this finding as evidence for the dentate nucleus functioning as a short-latency auditory relay for direct transmissions to the motor cortex. Besides the motor cortex, the rostral thalamus appears to be the target of the most rapid transmissions from the dentate (Woody et al., 1998).

Thus, while auditory input also recruits cortico-cerebello-thalamic circuits, including a descending pathway from the temporal cortex to the cerebellum via the pontine nuclei (Pastor, 2008), there may also be a direct ascending pathway to the cerebellum, which bypasses the “classical” auditory pathway that reaches the auditory cortex via the lateral lemniscus, the inferior colliculus, and the medial geniculate body of the thalamus. This pathway via the cerebellum is probably involved in primary, shortest latency, ascending auditory transmission (Wang et al., 1991; Woody et al., 1998). In order to speculate about the functional significance of this pathway, it is necessary to consider some limiting aspects first. Altman et al. (1976) report higher sensitivity in cats for interaural time and intensity differences than for frequency, intensity

or duration parameters per se. This finding, combined with a relatively small number of neurons that project from the cochlear nucleus to the cerebellum may rule out a detailed tonotopical organization of the cerebellar cortex, while it is probably convenient for sound localization (Huang et al., 1982). It has been speculated that the function of the cerebellar auditory neurons is related to target-localization, the localization of sound-making, and the subsequent regulation of tracking behavior (Huang and Liu, 1990). Thus, in combination with the motor aspect of cerebellar function, the cerebellum may be involved in the quick orientation of the head and the eyes towards sounds in the environment (Aitkin and Boyd, 1975). Such initial automatic orienting to an event may precede later stages of sustained attention to the temporal structure of successive events omitted by the same source and originating from the same location. Hence, if an analogous pathway exists in humans, it should provide the cerebellum with the opportunity to perform the initial steps of temporal processing fast and automatically, i.e. without mediation by cortical sites. From an evolutionary perspective, the pathway via the cerebellum, involved in orienting towards, and maintaining of attention to potentially threatening events in the environment may have extended its function to adopt a similar role with respect to increasingly complex auditory temporal structure as it is encountered in music and speech. In case of a threatening event, the ability to localize and evaluate temporal structure in order to predict the temporal locus of future events may be vital, whereas in the case of complex continuous stimuli it may entail facilitated processing due to prospective adaptation to temporal structure. Coming back to the above example, an approaching car generates temporal structure which may entail predictions based on an evaluation of temporal inter-event relations. Predictions regarding the temporal locus of the car relative to one's own location may then be used to adapt behavior. Furthermore, continuous attention-dependent evaluation of temporal structure may play a role in the signaling of accelerations and decelerations, which in turn would require additional adaptation to temporal structure. A similar mechanism may in principle apply to other settings, e.g. a communicative situation. By speaking, an individual generates temporal structure which in turn may trigger the evaluation of temporal structure and predictive mechanisms in order to maintain attention and to eventually facilitate comprehension.

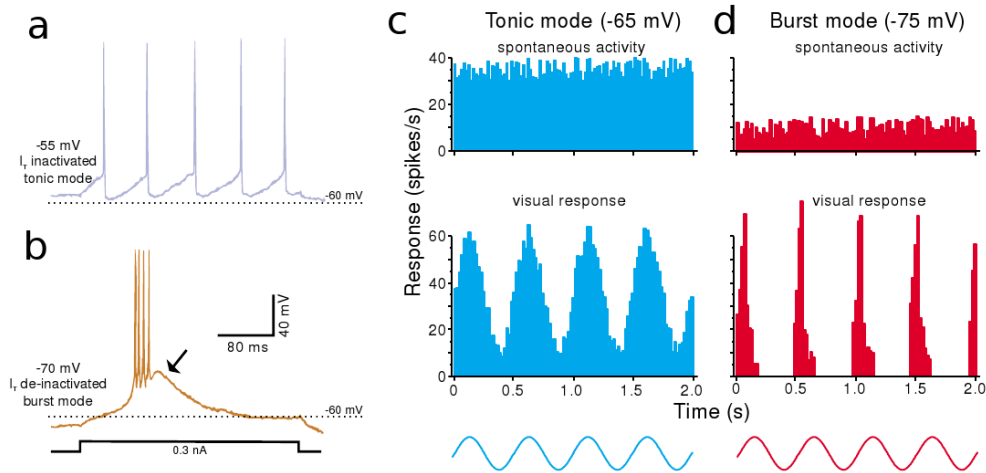
In this context, cerebellar temporal processing may be primarily related to the signaling of the presence, as well as to the temporally precise small scale or short-range processing of the input. While detecting the presence of a sound and sound localization are most likely located at

the lower end of this scale, its upper limits would have to be determined. This also raises the question as to how much temporal structure is needed in order to signal and to encode a salient change and to convey its presence as an event to the cortex. Several hundreds of milliseconds, as discussed earlier, are probably sufficient for a wide range of behaviorally relevant events, including events in the music and speech domain. In any case, the anatomical features of the cerebellum may provide a neural basis for the generation of an internal event-based representation of the temporal structure of an auditory signal. Regarding the dissociation of event-based and interval-based temporal processing, it is important to note that the temporally precise signaling of successive events inevitably also conveys temporally precise inter-event relations, i.e. intervals. The concept of duration pertains to this fact, as it applies to the interval between two successive events (Fraisse, 1984). However, whether auditory information reaches the cerebellum via the cortex or whether it is indeed conveyed via the cerebellum to the cortex, in either case, it is evident that the thalamus plays a central role in both routes and should therefore be discussed in more detail.

### **3.2 Towards the thalamus, and from the thalamus to the cortex**

According to Sherman and Guillery (2002; 2006) all thalamic relay cells respond to input in either a “tonic” or a “burst” firing mode. While the tonic mode allows preserving linearity, the burst mode affords better detectability of the input and provides an improved signal-to-noise ratio (Sherman and Guillery, 2006). Bursts follow the temporal properties of stimulation, thereby enhancing sensory event detection (He and Hu, 2002), and they can signal saliency of the input because the effect of a burst on the postsynaptic neuron is stronger than the effect of a single spike (Izhikevich, 2004). Burst and tonic firing are characterized by inter-spike intervals of about 100, and 10-30 ms, respectively. Interestingly, there is a slowdown of temporal response rate along the ascending auditory pathway from the thalamus (10 ms) to the auditory cortex (30 ms), that is necessary to integrate rapid auditory information in the cerebral cortex (Wang et al., 2008). More specifically, neurons in primary auditory cortex integrate information on a “segment-by-segment” basis and treat information outside a 30 ms time window as discrete events (Wang et al., 2003). This may coincide with the concept of a “central processing unit” (Pöppel, 1978), i.e.

the fact that information within 30 ms is treated as co-temporal (Pöppel, 1997). This in turn relates to earlier notions concerning quantized temporal processing in a “discrete moment” or a “perceptual moment” (for discussions see Fraisse, 1984; Pöppel, 2009). One may speculate that part of the reason for such limit eventually reflects a physiological constraint in temporal resolution in which the thalamus, and possibly the two thalamic firing modes, play a role. At the level of the cortex, this may be reflected in the asymmetric sensitivity of the two hemispheres to auditory stimuli in general, and speech stimuli, in particular, as well as the range for acceptable temporal modifications of vowel segments in isolated words and in sentences (Kato et al, 1998; Hickok and Poeppel, 2000; Zatorre and Belin, 2001; Hickok and Poeppel, 2007). More specifically, the left hemisphere shows finer acuity in temporal resolution whereas the right hemisphere samples input in longer temporal windows of integration, with damage to the left hemisphere impairing the order discrimination for two brief events (Allard and Scott, 1975; Hammond, 1982). This difference may be rooted in the differentiated encoding of input characteristics already at the level of the thalamus and/or earlier processing stages such as the cerebellum. If, for example, sine wave grating is used as a visual stimulus, the thalamic bursts encode temporal characteristics of the stimulation (Sherman and Guillery, 2002). In this case, they occur approximately at phase zero of the underlying oscillation (Fig. 8).



**Fig. 8.** Adopted from Sherman (2001). The original figure legend reads: *Some properties of burst and tonic firing recorded intracellularly from relay cells of the lateral geniculate nucleus of cats; redrawn from ref. 3. (a, b) Responses of a cell recorded in vitro in a slice, showing the different response of the cell in burst and tonic mode to the same depolarizing current injection (bottom trace); this current injection was imposed on top of a holding current (not shown) used to change the standing membrane potential to  $-55$  mV (a) or  $-70$  mV (b). When initially depolarized and in tonic mode (a), the current pulse evokes a steady stream of unitary action potentials. When initially hyperpolarized and in burst mode (b), the same current pulse evokes a  $\text{Ca}^{2+}$  spike (arrow), with, in this example, four action potentials riding its crest. Because these properties are common to all thalamic relay cells, they would apply as well to the thalamic cells studied by Swadlow and Gusev. (c, d) Responses of a cell recorded in vivo during light anesthesia. All average response histograms are generated from one cell. Current passed through the recording electrode could keep the average membrane potential relatively depolarized and thus place the cell in tonic mode (c) or hyperpolarized and thus in burst mode (d). Top histograms show spontaneous activity; bottom ones, responses to a sinusoidal grating drifted through the receptive field. The sine waves under each set of histograms show the contrast changes as the grating drifts through the receptive field.*

It is hence tempting to speculate that burst firing is sensitive to salient changes, and more specifically to increases, in the energy level of the stimulus. This may also represent a mechanism that is capable of marking the “time tags” of events which define their position in a sequence (Pöppel, 1978). Essentially, these properties of the burst mode make it suitable to convey an event-based representation of temporal structure (“when”), to cortical levels of temporal processing, whereas tonic firing transmits a more detailed linear representation



(“what”), of the input in order to access memory representations. Individual neurons can encode different stimulus features into distinct spike patterns, with the timing of bursts being much more precise than the timing of single spikes (Kepes and Lisman, 2003). Hence, driving input from the cerebellum may be encoded primarily via burst firing in order to convey a precise representation of event-based temporal structure. In contrast, driving input via the classical auditory pathway to the medial geniculate body of the thalamus may be encoded primarily, though not exclusively, via tonic firing to preserve its linearity and to generate a sufficiently detailed representation of formal structure. In guinea pigs, it has been shown that the lemniscal part of the medial geniculate preserves stimulus characteristics and depends on a tonic mode of neuronal discharge, whereas nonlemniscal transmission is characterized by bursts and may be involved in other aspects of sensory processing (He and Hu, 2002). However, if the medial geniculate is capable of responding to input in the burst and the tonic mode, then what is the function of the proposed auditory pathway via the cerebellum?

In order to answer this question it is necessary to consider the targets of thalamic output, and more specifically, the medial geniculate body as well as the supragenulate nucleus and its connections to temporal, but also to frontal cortices. For example, Bignall (1970) observed click evoked responses in the frontal cortex of monkeys after complete removal of the temporal lobe, the cerebellum, and the medial thalamus. This finding raises the possibility of direct projections to the dorsal frontal cortex from the medial geniculate. However, the medial geniculate is not the only thalamic nucleus that may project auditory information to the frontal cortex. Retrograde transport of tracers after injections into the prefrontal cortex of bats labeled cells in the auditory thalamus, thus identifying a pathway that may bypass auditory centers in the midbrain and cortex (Kobler et al., 1987). More specifically, Kurokawa et al. (1990) found anterograde labeling of cells in the medial agranular area of the frontal cortex as well as the auditory areas of the temporal cortex after injections into the supragenulate of rats. Reciprocal labeling was found after injections into the supragenulate and the cerebellar fastigial nucleus in cats, indicating a cerebello-thalamic connection (Katoh and Deura, 1993). The supragenulate is connected to the superior colliculus (Tanaka et al., 1985; Katoh et al., 1995). It responds to auditory stimulation, has multisensory features, with fine spatial and temporal tuning of its neurons, and may play a role in motion perception in order to adjust motor behavior in response to environmental challenges (Benedek et al., 1997; Paróczy et al., 2006). It is also implicated in the combined

processing of visual and auditory information (De la Mothe et al., 2006; Hackett et al., 2007). Correspondingly, Bignall (1970) considers the target of the frontal projections to be a “polysensory” area. Kurokawa et al. (1990) conclude that the supragenulate may mediate ascending auditory information to both premotor and temporal cortices. These connections consist of separate neuronal groups that are different in size and shape, with the target of the frontal projection being located in area Fr2, which corresponds to the SMA in monkeys (Kurokawa and Saito, 1995). Thus, in addition to input conveyed via the classical auditory pathway to the auditory cortex, an event-based internal representation of temporal structure, generated by the automatic cerebellar temporal processing system, may be relayed primarily via thalamic burst firing to the SMA.

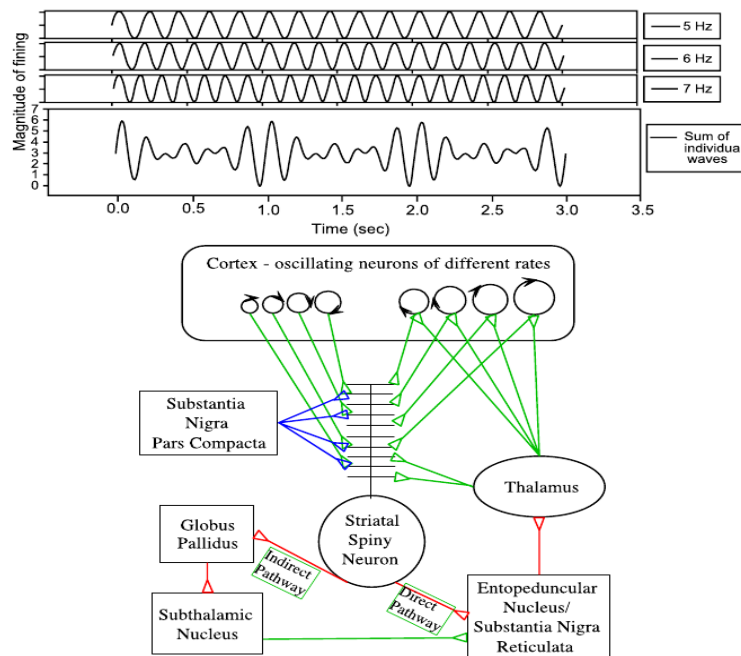
Burst firing is assumed to signal changes in the environment, thereby providing a “wake-up call” which strongly activates cortical cells (Sherman, 2001). If directed at the SMA, such a call may have profound consequences for temporal processing. As indicated above, the pre-SMA has connections to both the prefrontal cortex and the basal ganglia. Hence, an intriguing possibility for a functional interpretation of the thalamic connections to the frontal cortex would be to assume a “wake-up call” for attention. In this context, an increase in the energy level of a stimulus, i.e. a “ramped” contour is most likely behaviorally more relevant than a similar decrease in energy, i.e., a “damped” contour. It may signal the appearance of an event while a decrease in energy may signal its disappearance. Experimental lesions to the cerebellum can lead to disturbances of the orienting response and in attention to auditory stimuli (Altman et al., 1976). These functions could be interpreted as subserving “tracking behavior” (Huang and Liu, 1990; Huang et al., 1991) in the most general sense, i.e. the orienting and maintaining of attention to events in the environment. Moreover, with successive events it becomes necessary to keep track of temporal structure in order to adapt behavior accordingly, which in turn may recruit temporal processing.

DAT suggests that in order to track an event in real time it is necessary to not only allocate attention to the right place but also at the right time (McAuley et al., 2006). In any case, attentive processing of temporal structure sets the stage for attention-dependent temporal processing, which has been associated with cortico-striato-thalamo-cortical circuits. The term “attention-dependent” entails no a priori differentiation of explicit and implicit temporal processing (Coull and Nobre, 2008). Rather, it is used to delimit temporal processing

mechanisms, which require attention from earlier automatic mechanisms (Buhusi and Meck, 2005). Besides top-down processes, i.e. the allocation of attention to time, “attention-dependent” comprises stimulus-driven bottom-up processes, i.e. the allocation of attention in time. Considering the latter, the proposed initial wake-up call for attention via the thalamus may be necessary to initiate temporal processing in cortico-striatal circuits. Once attention is directed towards a temporally structured input, successive events may serve as attractors to both, adaptive attention oscillations in the sense of DAT, and/or non-adaptive cortical oscillations that convey input to the basal ganglia, and more specifically, to striatal medium spiny neurons as suggested by the SBF model (Matell and Meck, 2004). In both cases, an incoming event may provoke phase resetting of the respective oscillators. However, whereas adaptive oscillations adjust their phase and period in order to track evolving temporal structure, the non-adaptive oscillations implemented in the SBF model start to oscillate at different frequencies, thereby generating a “time-code” for a specific interval. On this basis, successive events probably entail both, the opportunity to maintain and synchronize attention with temporal structure, as well as the opportunity to generate explicit or implicit predictions concerning future events. In either case, the inevitably encoded temporal inter-event relations may represent the computational basis for the subsequent evaluation of temporal structure and the recognition of a temporal pattern.

### **3.3 From frontal cortices to the basal ganglia – and back**

Perhaps the most striking anatomical and functional feature of the basal ganglia system is its embedding into a “looped” architecture, which allows for repetitive processing of information in subcortico-cortical circuits (Alexander et al., 1986; Middleton and Strick, 2000). As indicated, this aspect is central to the influential SBF model of temporal processing. The SBF model suggests that temporal processing is based on the coincidental activation of the basal ganglia, and more specifically, striatal medium spiny neurons by ensembles of cortical neural oscillators (Buhusi and Meck, 2005; Meck et al., 2008). Each striatal medium spiny neuron receives input via 10.000 to 30.000 separate axons, thus raising the possibility that these neurons integrate large numbers of inputs coming from different areas of the cortex as a basis for interval-based temporal processing in cortico-striato-thalamo-cortical circuits (Matell and Meck, 2004; Fig. 9).

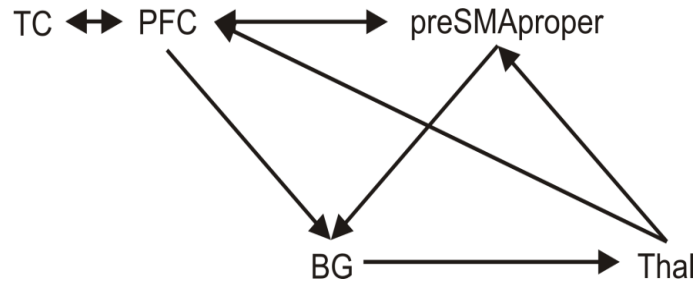


**Fig. 9.** Adopted from Matell and Meck (2004). The original figure legend reads: *A graphic representation of an oscillatory-based timing circuit. The top of the figure shows three different frequency oscillating signals (cortical ensembles) and the unweighted summation of their output (striatal input) over time. As can be seen, the output periodicity is greater than that of the inputs, demonstrating the potential of this type of model to bridge the millisecond time scale of the brain to the second to minute time scale of interval timing. The lower half of the figure shows information flow through the cortico-striatal-thalamo-cortical loop. Arrows indicate the direction of information flow. Red arrows are GABAergic, green arrows are glutamatergic, blue arrows are dopaminergic. The dopaminergic input to the striatal neuron provides a reinforcement signal to selectively weight cortical and thalamic inputs. Different striatal neurons participate in direct and indirect pathways.*

However, among these sources of input to the striatum via the prefrontal cortex the SMA is of particular interest. From a structural point of view, the SMA consists of at least two well distinguishable subareas, the rostral pre-SMA and the caudal SMA-proper (Picard and Strick, 2001; Klein et al.; 2007). The VCA line, a vertical line at the level of the anterior commissure, demarcates the pre-SMA from the SMA-proper (Picard and Strick, 2001; Lehericy et al., 2004). These subareas differ in their connections to other structures of the brain, including the

cerebellum, prefrontal, premotor and primary motor cortices, as well as the basal ganglia. Connections to the pre-SMA originate in the non-motor part of the cerebellar dentate, whereas the SMA-proper is connected to its motor part (Akkal et al., 2007). Among other structures, the pre-SMA is connected to the prefrontal cortex, including superior and inferior frontal gyri, while the SMA-proper is connected to the corticospinal tract, the precentral gyrus, as well as to the primary motor cortex (Picard and Strick, 2001; Johansen-Berg, 2004). Both subareas are connected to the basal ganglia, with the connections maintaining a rostrocaudal organization (Postuma and Dagher 2006; Draganski et al., 2008).

One may speculate that the connections of the pre-SMA to prefrontal areas, in concert with its connections to the basal ganglia, play a crucial role in the “tagging of temporal attributes” (Pastor et al., 2006) and in the temporal sequencing of information retrieved from memory via connections to temporal cortices. This process essentially integrates formal and temporal structure, thereby adding an explicit temporal aspect to the sequencing of discrete events into motor and/or cognitive patterns (Graybiel, 1997). More specifically, the decision to act and to produce a sequence of successive events may recruit connections from prefrontal areas to the pre-SMA. The pre-SMA may then engage in the initiation and the temporal linking of actions and their effects, a function that in essence corresponds to a temporally specific predictive mechanism (Moore et al., 2010). Furthermore, in speech production it may be necessary to sequence information retrieved from memory, i.e. formal structure, according to a “pacemaker” signal generated by the interplay of pre-SMA and basal ganglia, a function that is probably comparable to the “initiation” map proposed by the DIVA model of speech production (Tourville and Guenther, 2011). In other words, recruitment of the SMA may be necessary in order to specify a point in time according to which an action is implemented (Fig. 10).



**Fig. 10.** Production versus perception of temporal structure. The decision to act, i.e. to produce a sequence of events (PFC) calls for memory representations of events (temporal cortex, TC) and/or the respective action plans (formal structure). It also recruits the pacemaker function inherent to the interplay of pre-SMA, basal ganglia (BG), and thalamus (THAL) in order to initiate action and to establish sequential relations among events (temporal structure). Implementation of a sequence of events recruits connections to SMA-proper and motor cortices. Exposure to a sequence of events in perception relays an event-based representation of temporal structure to the thalamus (THAL), which is “tagged” by the pre-SMA and calls for attention (PFC). If attention is oriented towards a sequence of events, the event-based representation initiates and/or provides attractors to dynamic attending and/or attention-dependent temporal processing oscillations. Attention-dependent temporal processing encodes temporal inter-event relations (intervals) and conveys this information to working memory (PFC). Information about the temporal structure of a sequence of events may then be stored and successive intervals may be compared in order to extract patterns. However, regular temporal structure not only allows extracting patterns and pattern-based predictions about temporal structure, it also facilitates the stimulus-driven maintenance of attention, thereby reducing the susceptibility of the whole system to errors and stabilizing the whole process.

Temporal fine-tuning of formal structure relative to this pacemaker signal and the control of the respective articulators may then recruit cerebello-frontal connections as well as connections to premotor and motor cortices. The result of this merging process, a unit comprising formal and temporal characteristics may then be realized in articulation. The whole process can be likened to the “translation from the spatial distribution of memory traces to temporal sequence” (Lashley, 1951, p. 128).

In perception, connections to premotor and primary motor cortices probably afford rapid reactions, reflecting a potentially vital bias to react to events in the environment. Thereby, the SMA may have an important function in linking cerebellar automatic, short-range, and event-based temporal processing to attention-dependent, longer-range, and interval-based temporal processing. Furthermore, following initial and sustained cerebellar wake-up calls, connections

from the pre-SMA to the prefrontal cortex may contribute to both, the maintenance of attention and the evaluation of temporal structure, possibly by signaling temporal information into working memory. In addition to the direct stimulus-driven processing of regularity, this more indirect evaluation of temporal structure probably affords comparability of successive intervals in order to assess regularity in temporal structure. This process may also take advantage of the possibility of cyclic processing in cortico-striato-thalamo-cortical circuits. Indeed, it has been suggested that temporal processing and working memory may rely on the same prefrontal processing units (Lewis and Miall, 2006). In turn, these stages of temporal processing may represent precursors for the generation of predictions concerning temporal structure by inferring future events on the basis of an evaluation of past events, as well as for a subsequent long-term storage of temporal structure.

### **3.4 Some missing components**

Although the core components of a dedicated integrative temporal processing network have been outlined in the preceding sections, the introduced network is by no means complete. Like other working models it is convenient but simplified to the extent that many open ends remain. Some of the most obvious omissions concern input to the basal ganglia from other cortical areas, including temporal cortex (Yeterian and Pandya, 1998; Budinger et al., 2000), direct cortico-cortical connections via white matter pathways such as the arcuate fasciculus (Rilling et al., 2008), the descending auditory pathway and connections from temporal cortex to the cerebellum via the pontine nuclei (Perales et al., 2006; Pastor et al., 2008), ascending projections from the cerebellum to temporal cortex (Heath and Harper, 1974), as well as direct subcortico-subcortical connections. For example, via the thalamus, the motor and non-motor domains of the cerebellar dentate are also connected directly to the striatum, and more specifically, the external segment of the globus pallidus (Hoshi et al., 2005). One may speculate that top-down connections from the cortex provide information to the cerebellum that is useful in the processing of formal structure in order to generate predictive models, whereas bottom-up connections to the earliest stages of sensory processing play a role in coding the precise timing of predictions (Ghajar and Ivry, 2009) by transmitting event-based “wake-up-calls” for attention, which serve as attractors for attention

oscillations and set the stage for attention-dependent temporal processing. In other words, the processing of formal structure in feed-forward and feed-back networks may afford predictions concerning *what* event happens next, whereas oscillations may generate predictions concerning *when* the next event occurs (Buzsaki and Draguhn, 2004).

There is also evidence for reciprocal connections between the cerebellum and the basal ganglia, which provide each structure with the opportunity to influence the other (Bostan and Strick, 2010; Bostan et al., 2010). Evidence for these structural connections substantiates speculations regarding functional connectivity between the cerebellum and the putamen in temporal processing (O'Reilly et al., 2008). Besides bidirectional connections, entirely subcortical loops involving the basal ganglia may also have to be considered (McHaffie et al., 2005). Another important issue concerns the relative weighting of output from and input to key structures of the network. For example, the thalamus receives most of its input not from subcortical structures but from the cortex (Sherman and Guillery, 2006), while the SMA receives considerably more input from the basal ganglia than from the cerebellum (Rouiller et al., 1994; Sakai et al., 1999; Akkal et al., 2007). These mere weightings probably reflect important functional specifications. Potentially, these weightings are compatible with the proposed network, in which a specific cerebellar output could be processed repeatedly in cortico-striato-thalamo-cortical circuits in order to evaluate its temporal structure. Eventually, it may turn out necessary to integrate some of these missing components into a more detailed account of dedicated temporal processing, however, at this stage such account is highly speculative and beyond the scope of this work.





### **III. Empirical Part**



#### **4. Empirical part - overview**

The following empirical part consists of three individual articles. These articles provide a representative contribution to the outlined framework of a dedicated integrative temporal processing network introduced beforehand. While parts of this network have previously been discussed in relation to speech processing (Kotz et al., 2009; Kotz and Schwartz, 2010), these articles take a more general stance with respect to temporal processing. All articles appear unchanged in the form of the published manuscripts. Titles and numbering of the sections, as well as the original reference style is maintained throughout the articles, with individual references listed separately at the end of each article.

Taken together, the selected articles cover behavioral, neuroimaging, as well as meta-analytic methods. The first article describes a study that is concerned with adaptive sensorimotor synchronization in patients with focal basal ganglia lesions and healthy control participants. Article two discusses EEG data that was obtained by contrasting temporal regularity and temporal irregularity in both pre-attentive and attention-dependent experimental settings. Finally, the third article presents a meta-analysis of fMRI studies which dissociates the specific roles of pre-SMA and SMA-proper in temporal processing.



## **Chapter 3**

### **Article I**

- 5. The impact of basal ganglia lesions on sensorimotor synchronization, spontaneous motor tempo, and the detection of tempo changes (Behavioural Brain Research, 216 (2011), 685-691)**



**The impact of basal ganglia lesions on sensorimotor synchronization, spontaneous motor tempo, and the detection of tempo changes**

Michael Schwartz \* , Peter E. Keller , Aniruddh D. Patel and Sonja A. Kotz

*Max Planck Institute for Human Cognitive and Brain Sciences  
Independent Research Group "Neurocognition of Rhythm in Communication", Leipzig, Germany  
Max Planck Institute for Human Cognitive and Brain Sciences  
Max Planck Research Group "Music Cognition and Action",  
Leipzig, Germany  
The Neurosciences Institute, San Diego, USA*

18 text pages, 8 figures, 1 table

Corresponding author\*:

Michael Schwartz

Max Planck Institute for Human Cognitive and Brain Sciences

Research Group "Neurocognition of Rhythm in Communication"

Stephanstrasse 1a, 04103 Leipzig, Germany

Tel: +49 341 99402473

Fax: +49 341 99402260

Email: [schwartz@pbs.mpg.de](mailto:schwartz@pbs.mpg.de)



## **Abstract**

The basal ganglia (BG) are part of extensive subcortico-cortical circuits that are involved in a variety of motor and non-motor cognitive functions. Accumulating evidence suggests that one specific function that engages the BG and associated cortico-striato-thalamo-cortical circuitry is temporal processing, i.e. the mechanisms that underlie the encoding, decoding and evaluation of temporal relations or temporal structure. In the current study we investigated the interplay of two processes that require precise representations of temporal structure, namely the perception of an auditory pacing signal and manual motor production by means of finger tapping in a sensorimotor synchronization task. Patients with focal lesions of the BG and healthy control participants were asked to align finger taps to tone sequences that either did or did not contain a tempo acceleration or tempo deceleration at a predefined position, and to continue tapping at the final tempo after the pacing sequence had ceased. Performance in this adaptive synchronization-continuation paradigm differed between the two groups. Selective damage to the BG affected the abilities to detect tempo changes and to perform attention-dependent error correction, particularly in response to tempo decelerations. An additional assessment of preferred spontaneous, i.e. unpaced but regular, production rates yielded more heterogeneous results in the patient group. Together these findings provide evidence for less efficient processing in the perception and the production of temporal structure in patients with focal BG lesions. The results also support the functional role of the BG system in attention-dependent temporal processing.

Keywords: basal ganglia, temporal processing, tapping, synchronization, lesion, tempo change, attention

## 1. Introduction

Individuals continuously adjust their behavior to environmental changes. The underlying adaptive process unfolds in time and involves the cyclic processing of motor and sensory information [1]. The question arises whether this cyclic processing is merely intrinsically temporal or to what extent temporal information is actually processed and used as a source of information in itself. Some internal representation of temporal structure is a prerequisite for efficient timing, which in turn bears the potential to optimize adaptive processes. Efficient timing of behavior implies temporally appropriate reactive and proactive actions. The latter depend on anticipation and predictions about the temporal structure of future changes or events as well as the ability to temporally align behavior with these events. Both aspects converge in sensorimotor synchronization (SMS).

SMS is a specific form of adaptive interaction with the environment. It is an extensively studied process that merges motor and non-motor components in a single setting. SMS can be characterized as the temporal coordination of a motor rhythm with an external rhythm [for reviews see 2, 3]. This temporal coordination can be conceived as synchronization. Synchronization denotes the “adjustment of rhythms of oscillating objects due to their weak interaction” [4]. An oscillation is defined by its phase, relative to another oscillation, and period, and provides a means to describe the temporal relation of the events that constitute a rhythm in terms of frequency, i.e. the repetition of similar events in a specific amount of time. Complex rhythmic activity and synchronization between different rhythms constitute central aspects of life. Physiological rhythms interact continuously with each other and the environment in order to mediate between internal and external events [5]. In cognition, this implies adaptation of internally-generated to external rhythms via unidirectional coupling which eventually leads to stimulus-driven synchronization of behavior.

Both SMS and temporal processing have been modeled on the basis of oscillations and the fundamental dissociation of automatic and controlled sub-processes. For example, temporal processing is hypothesized to rest on the coincidental activation of medium spiny neurons in the BG by ensembles of cortical neural oscillations [6, 7]. In SMS, the period of an adaptive oscillatory timekeeper is assumed to reflect the temporal structure of the pacing signal, thereby establishing a reference for the timing of successive motor commands [8]. In this context, the

current study investigates a combination of these aspects by providing BG patients and controls with an oscillatory perceptual input whose temporal structure needs to be exploited to generate oscillatory motor behavior. Error correction mechanisms adjust the phase and period of the internal timekeeper oscillation if it is confronted with a perturbation, i.e. a change in the temporal structure of the pacing signal. These error correction mechanisms are dissociable based on their dependence on attention, the intention to adapt, and awareness of a tempo change [9]. Whereas phase correction depends solely on the intention to maintain synchrony and can therefore be considered automatic, period correction depends also on attention and awareness of the tempo change.

A comparable dissociation between automatic and controlled mechanisms has been proposed with respect to temporal processing [10]. More specifically, the cerebellum (CE) performs automatic or pre-attentive, short-range, event-based temporal processing, while in parallel, the BG and cortico-striato-thalamo-cortical circuitry engage in attention-dependent, longer-range, interval-based temporal processing [7, 11, 12]. Attention or the ability to attentively detect a change in temporal structure may therefore not only decide upon the type of error correction, but also upon the primary temporal processing system. Temporal structure may thereby influence cognitive processes, e.g. as the basis for attentional set shifting and sequence coordination [13]. This view is consistent with Dynamic Attending Theory [DAT, 14], which proposes that attention can be modeled as a self-sustained oscillation capable of entrainment. Within the framework of DAT, the temporal structure of a stimulus guides the allocation of attentional resources thereby evoking stimulus-driven attending [15]. On this basis, attentive adaptation to tempo change in SMS would depend on the parallel engagement of pre-attentive and attention-dependent temporal processing systems, as well as phase and period correction to adjust internal timekeeper and/or attention oscillations.

The role of the BG in temporal processing and in SMS has been investigated primarily in patients with Parkinson's Disease (PD), albeit with mixed results [16, 17, 18]. Studies involving PD patients also suggest difficulties in beat extraction and the comparison of rhythmic sequences [19]. However, PD is a progressive neurodegenerative disease, and besides medication and different PD subgroups [20] some of the heterogeneity of the respective results may be due to the variable extent of cortical damage in this population, which can be minimal or absent in patients with BG lesions [21, 22]. Studies on SMS involving patients with focal lesions of the BG are

scarce. Aparico et al. [23] used a synchronization-continuation paradigm and found no evidence for impaired temporal processing performance in this group. Different tasks, stimulus characteristics, and cognitive sets add further complexity to the identification of specific BG and cerebellar temporal processing functions [24].

Besides attention, temporal range seems to be an important factor, as temporal processing evolves across different timescales that may map onto different physiological and psychological mechanisms [10, 24, 25]. A well-defined boundary between short-range and longer-range temporal processing remains elusive, although values around 500 ms [26] and close to 1000 ms [27] have been suggested. Fraise [28] emphasizes that synchronization is most stable for tempi between 400 and 800 ms, while the intermediary tempo of 600 ms is most representative for unpaced, spontaneous motor activity. This has been confirmed in more recent studies [29] that also found a correlation between individual spontaneous motor tempo (SMT) and a preferred perceptual tempo [30]. It corresponds to the “indifference interval” or “indifference zone” that is neither systematically overestimated nor underestimated [28, 31]. A tempo of 600 ms is within the range for optimal pulse sensation [32] and tempo sensitivity [33, for a review see 34]. Although originating from a different perspective, Karmarkar and Buonomano [35] hypothesize that temporal processing between 400 and 800 ms may be accurately performed by mechanisms underlying both time perception and time estimation. Hence, the SMS task in the current study incorporated a base tempo of 600 ms and tempo changes that induced shifts relative to this base tempo. This procedure should perturb the synchronization of internal timekeeper and/or attention oscillations. We expected that damage to the cortico-striato-thalamo-cortical attention-dependent temporal processing system due to BG lesions should lead to difficulties in the evaluation of temporal structure and consequently in maintaining attentive synchrony. These difficulties should compromise the ability to detect and to assess a tempo change which should in turn lead to a lesser degree of attention-dependent period correction during SMS in the patient group, while automatic phase correction should be preserved.

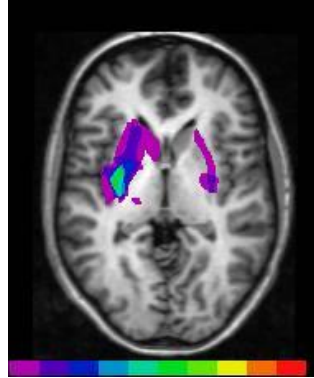
We assessed SMT before and after the main SMS task to explore whether the SMT of patients with BG lesions differs from that of healthy controls and whether it would be influenced by the intervening SMS task. For example, stronger reliance on the unimpaired cerebellar short-range system in the patient group may be reflected by a preference for faster SMT rates. SMT is not constrained by simple biomechanical mechanisms [28] and in the absence of an external

pacemaker it has to rely on internally generated temporal structure and simultaneous monitoring of temporal regularity. We hypothesized that faster SMT rates in the patient group could reflect stronger reliance on the unaffected cerebellar short range temporal processing system. BG lesions should compromise both the consistency of internally generated temporal structure and the monitoring process, which in turn should lead to increased tapping variability in the patient group. In general, a better understanding of these fundamental mechanisms and the way they are altered in this specific patient group is not only important for modeling the mechanisms underlying the adaptive interaction with the environment but may also be helpful in optimizing the temporal structure of compensatory strategies used in therapeutic settings.

## **2. Materials and Methods**

### **2.1 Participants**

10 patients with focal lesions of the BG due to stroke (mean 6.2 years post lesion onset, SD = 2.5) and 10 healthy controls (one woman per group) participated in the current study. None had prior experience with finger tapping in an experimental setting. The group comprised eight patients with partial middle central artery infarction and two patients with intracerebral hemorrhage. Lesions were left-lateralized in eight, and right-lateralized in two patients. In seven patients lesions affected anterior and posterior parts of the striatum. In two patients lesions were focused in the posterior striatum, and in one patient in the anterior striatum, respectively. A structural overlay of the lesions is depicted in Fig 1. Ages ranged from 30 to 68 years and mean age was 46.7 years (SD = 13.3). Healthy controls were recruited via the database of the Max-Planck Institute for Human Cognitive and Brain Sciences and matched the patients in terms of age, education (in years), gender and handedness. All participants received a compensatory fee and gave their informed consent before they were tested. The study was approved by the local medical ethics committee at the University of Leipzig.



**Fig 1.** Structural overlay of basal ganglia lesions. Green shades are associated with maximum lesion overlap, whereas purple shades are associated with minimal lesion overlap.

## **2.2 Spontaneous motor tempo task**

To assess the SMT of patients and controls we applied a similar procedure as McAuley and colleagues [29]. Participants were asked to tap regularly at their most comfortable rate for a short period of time. A single tone sounded after 31 taps (30 inter-tap intervals (ITI)) were recorded. No auditory feedback was given. This task was carried out before and after the main SMS task in order to test for the potential influence of this task on SMT rates.

## **2.3 Sensorimotor synchronization task**

All participants used the index finger to tap on an electronic percussion pad (Roland SPD-6) placed on a table in front of them. The pad was connected to a Windows PC via a MIDI interface. A quiet “thud” sound with intensity proportional to tapping force was produced upon impact with the rubber surface of the pad. This sound was further attenuated by the use of headphones. However, no digital sound output was provided. The manual mode of the pad was selected (as opposed to drumstick mode). Prior to the SMT and SMS tasks, all participants were allowed to

familiarize themselves with the setting, and to test different styles of tapping in order to find the most comfortable tapping position. Some participants decided to tap while holding their forearm above the pad, but most preferred to rest their hand on the pad. All patients tapped with their less affected ipsilesional hand in order to reduce possible confounds of impaired motor control. Some patients reported that they had used this hand more frequently in the average 6.2 years since lesion onset. Control participants tapped with their dominant right hand. The adaptive timing task applied in this study was the same as the one used by Repp and Keller [9] with the exception that the current base tempo was 600 ms instead of 500 ms.

Stimulus presentation and tap recording was controlled by a program written in MAX (<http://www.cycling74>) running on a Windows PC. Stimuli were presented via headphones (Sennheiser HD 202) at a comfortable intensity. A total of 100 pseudo-randomized synchronization-continuation trials were processed in 10 blocks of 10 trials each. 10 identical high-pitched piano tones (C8; 4176 Hz) were used as pacing stimuli during the synchronization phase of each trial. In eight trials per block the initial inter-onset interval (IOI) of 600 ms was presented six times and was then followed by tempo accelerations or decelerations with a magnitude of 30, 45, 60 or 75 ms for the three remaining IOIs. Two trials per block did not contain a tempo change and served as control sequences. Thus, if the trial contained a tempo change, it occurred between the 7<sup>th</sup> and 8<sup>th</sup> tone of the pacing sequence. Participants were instructed to start tapping with the third tone of the pacing sequence. An additional single tone of lower pitch (E7) marked the end of the continuation phase and served as a signal to stop tapping. Awareness of the tempo change was assessed by means of a perceptual judgment. At the end of each trial, participants reported orally whether they had perceived a deceleration, acceleration or no tempo change within the pacing sequence. Presentation of the next trial started two seconds after the experimenter recorded the decision via key press. All data were acquired during a single session of approximately 60 minutes.

Missing taps and taps that either followed the target position by more than 130 ms or preceded it by more than 150 ms were excluded from the analysis and are referred to as errors. For the control sequences, mean asynchrony (MA) between taps and pacing sequence tones, variability of asynchronies, mean ITI during synchronization and continuation, and variability for ITIs produced during synchronization and continuation were calculated. Adaptation to tempo changes was assessed in terms of mean ITIs, error correction and perceptual sensitivity to tempo

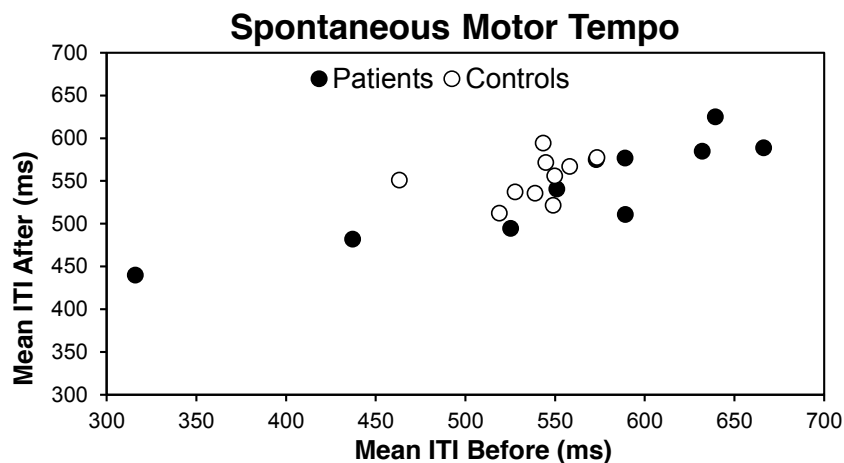
changes on five positions of interest (s0, s1, s2, s3, c). Position s0 corresponds to the ITI terminated by the tap that coincided approximately with the first tone at the new sequence tempo. This is followed by positions s1, s2 and s3. Position s3 thus corresponds to the ITI initiated by the tap coinciding approximately with the last sequence tone. Finally, c represents the average ITI during the whole continuation phase [9].

### **3. Results**

#### **3.1 Spontaneous motor tempo**

Mean SMT in the patient group was 551 ms (SD 105 ms) before, and 541 ms (SD 58 ms) after the SMS task. For the control group the corresponding values were 536 ms (SD 30 ms) before, and 552 ms (SD 26 ms) after the SMS task (Fig. 2). Distribution of SMT rates differed between the two groups. Levene's test of equality of error variances revealed that the patient group was more heterogeneous than the control group before,  $F(1.18) = 5.94$ ,  $p < .03$ , and after the SMS task,  $F(1.18) = 7.64$ ,  $p < .02$ . However, contrary to our prediction there was no unitary trend towards either shorter or longer ITIs. Instead, patients demonstrated both fast and slow SMT rates, while controls' SMT rates clustered around 550 ms.

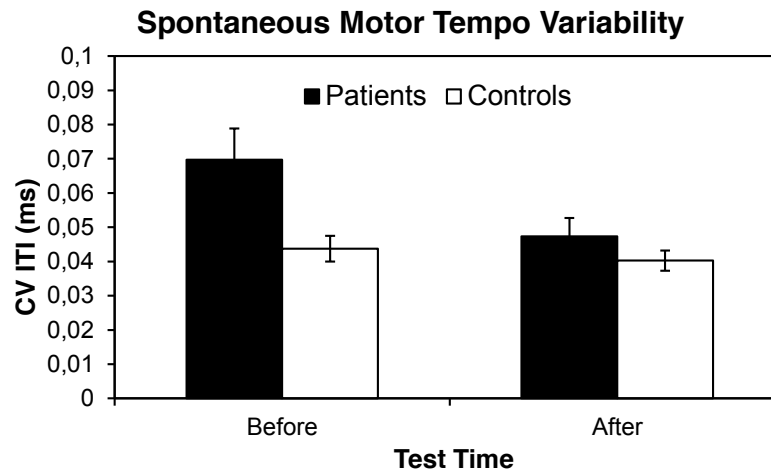




**Fig. 2.** Distribution of spontaneous motor tempo for patients with basal ganglia lesions and healthy controls before and after the adaptive timing task. ITI = intertap interval.

SMT variability was assessed by the coefficient of variation (CV) that was computed by dividing the standard deviation of individual ITIs within a trial by the mean ITI. Tapping variability was higher in patients than in controls (Fig. 3). Furthermore, variability was generally lower after the adaptive timing task than before it. This was the case both in patients and in controls. In this case, Levene's test of equality of error variances was not significant. A 2 x 2 ANOVA with factors group (patients vs. controls) and test time (before vs. after the adaptive timing task) yielded significant differences for group  $F(1.18) = 6.74, p < .02$  and test time  $F(1.18) = 6.45, p < .03$ ; but no significant interaction, group x test time  $F(1.18) = 3.44, p = .08$ . These results imply more variable generation of temporal structure in the patient group.

Due to erratic performance during the subsequent SMS task one patient and the respective control had to be excluded from all further analyses except for the detection task. Exclusion of these participants changed the results of the preceding ANOVA to group  $F(1.16) = 7.78, p < .02$ ; test time  $F(1.16) = 4.84, p < .05$ ; and group x test time  $F(1.16) = 3.84, p = .07$ .



**Fig. 3.** Coefficients of variation (CV) for the spontaneous motor tempo task for patients with basal ganglia lesions and healthy controls before and after the adaptive timing task.

### 3.2 Adaptive timing task

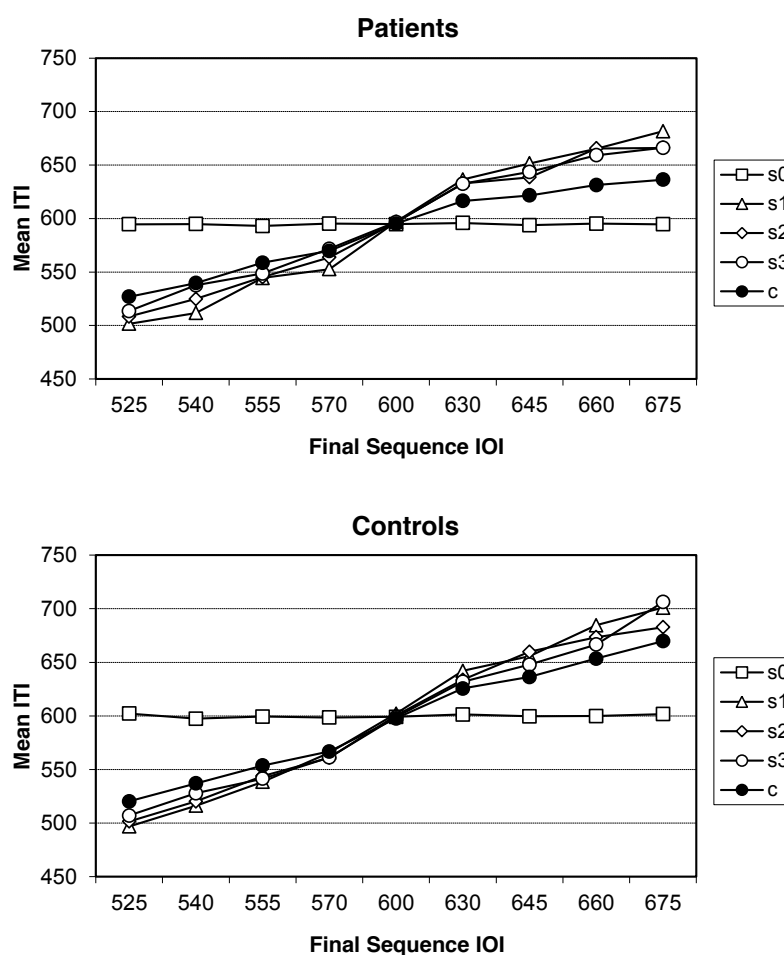
For the full sample of participants, the percentage of errors was 4.5% for patients and 1.4% for controls,  $t(18) = 1.90$ ,  $p = .07$ . However, one patient and the respective control were excluded from all further analyses. This patient tapped at a tempo independent of the pacing sequence tempo. Mean ITI was 497 ms for synchronization and 496 ms for continuation. The tapping was quite stable during synchronization ( $CV = .053$ ) and highly stable during continuation ( $CV = .036$ ). It is tempting to speculate that the tempo of the pacing sequence distracted the patient from tapping at a preferred rate (SMT before = 437 ms and SMT after = 482 ms). For the remaining participants, percentage of errors was 3.4% for patients and 1.5% for controls,  $t(16) = 1.34$ ,  $p = .16$ . Results for the control sequences without a tempo change are provided in Tab. 1. The negative values for MA indicate that the taps preceded the pacing stimulus, which is a typical finding for SMS in inexperienced tappers [36].

	Mean Asynchrony	CV Asynchrony	Mean ITI Synchronization	Mean ITI Continuation	CV ITI Synchronization	CV ITI Continuation
Patients	-31	0.048	596	595	0.057	0.061
Controls	-26	0.034	600	598	0.041	0.044

**Tab. 1.** Mean Asynchrony, mean intertap interval (ITI), and coefficient of variation (CV) of ITIs for patients and controls during synchronization and continuation.

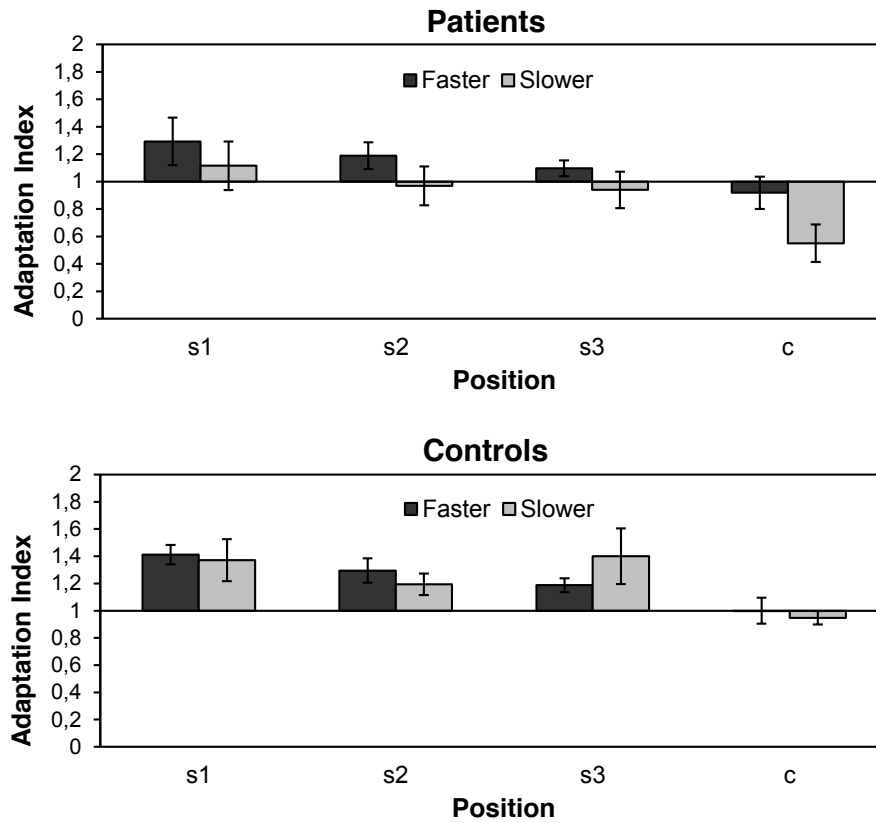
While the groups did not differ with respect to MA,  $t(16) = .34$ ,  $p = .74$ , the CV for asynchronies was higher for patients  $t(16) = 2.36$ ,  $p < .04$ . Mean ITIs, and CVs for synchronization and continuation were analyzed in separate 2 x 2 ANOVAs to test for the effects of phase (synchronization vs. continuation) and group (patients vs. controls). The ANOVA on mean ITIs revealed no significant differences, phase  $F(1,16) = .75$ ,  $p = .40$ ; group  $F(1,16) = .17$ ,  $p = .69$ ; phase x group  $F(1,16) = .02$ ,  $p = .90$ . However, the ANOVA on CV of ITIs yielded a significant effect for phase  $F(1,16) = 19.25$ ,  $p < .01$ , but not for group  $F(1,16) = .70$ ,  $p = .42$ , and no significant interaction phase x group  $F(1,16) = .055$ ,  $p = .82$ , indicating less variability during the paced synchronization phase. Together, these results demonstrate that the patients could principally synchronize their motor behavior with the auditory pacing sequences.

To examine the adaptive response to the tempo changes, mean ITIs were plotted as a function of final sequence tempo separately for all sequences, including the control sequences, for patients and controls for each sequence position of interest (s0, s1, s2, s3, c) (Fig. 4).



**Fig. 4.** Mean intertap intervals (ITI) for basal ganglia patients and healthy controls as a function of the final sequence inter-onset interval (IOI).

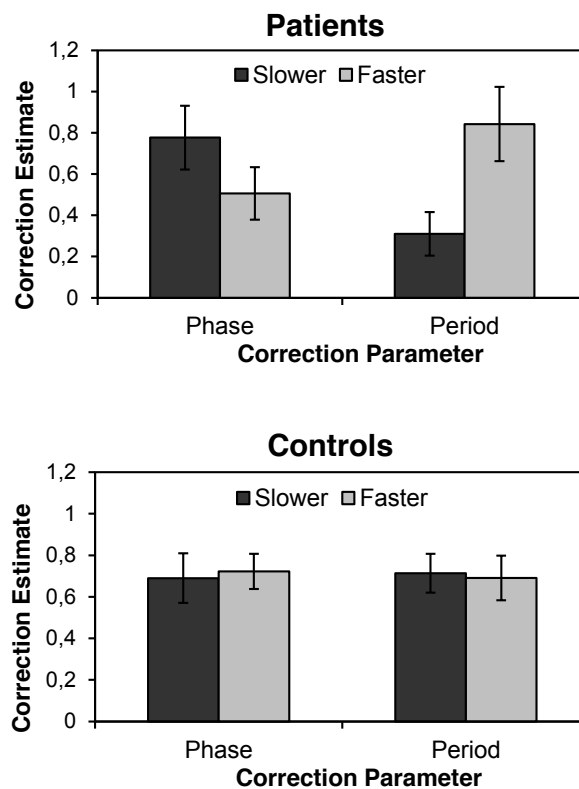
Regression lines were fitted to the slopes of these ITI functions and were used as adaptation indices (Fig. 5). A value of 1 represents perfect adaptation, values less than 1 indicate undercorrection and values greater than 1 overcorrection. Adaptation indices were computed separately for tempo increases (i.e., faster tempi with final sequence IOIs < 600 ms) and tempo decreases (slower tempi with final sequence IOIs > 600 ms).



**Fig. 5.** Adaptation indices for basal ganglia patients and healthy controls for the sequence positions following the tempo change (s1, s2, s3) and during continuation tapping (c).

A 2 x 2 x 4 ANOVA was conducted to examine the effects of group (patients vs. controls), tempo (faster vs. slower), and position (s1, s2, s3, c) on adaptation indices. The observed adaptation indices differed between the groups  $F(1.16) = 5.43, p < .04$  and between positions  $F(3.48) = 9.32, p < .01$ . Adaptation indices were generally higher in controls than in patients, and decreased across sequence positions in both groups. However, there were no significant interactions between group x tempo  $F(1.16) = 2.97, p = .10$  or position x group  $F(1.16) = .33, p = .57$ . Error correction was partitioned into phase correction and period correction according to the two-process model of error correction [8]. These types of error correction were estimated by determining the values of the parameters that led to the best fit between predictions based on the two-process model of error correction (implemented in MATLAB) and the observed adaptation

indices [9]. Average phase and period correction estimates for tempo increases and decreases are shown separately in Fig. 6 for patients and controls. The fact that these values are higher than those observed by Repp and Keller [9] may be attributed to the participants' relative inexperience with finger tapping (Repp and Keller tested highly trained tappers) and/or the slower base tempo employed in the current study (600 ms vs. 500 ms).



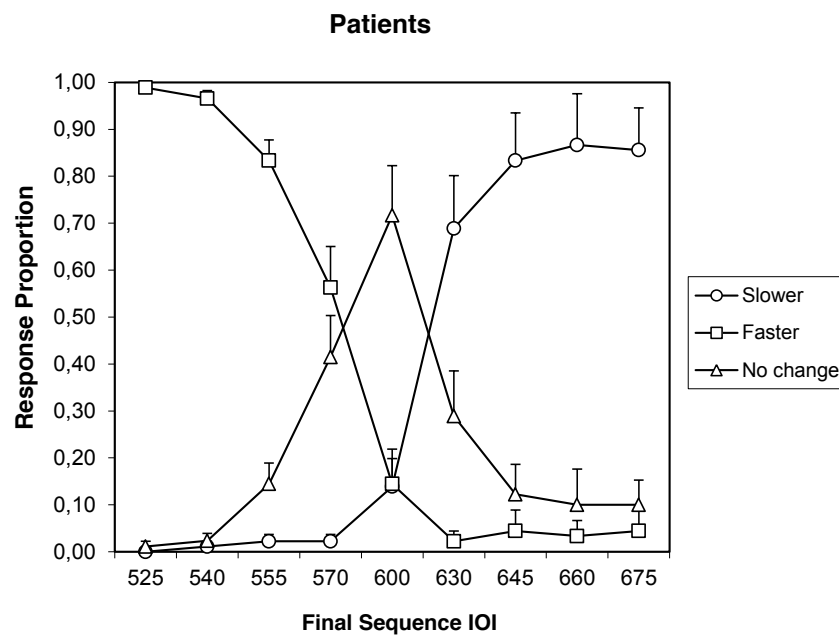
**Fig. 6.** Phase and period correction estimates for basal ganglia patients and healthy controls for tempo accelerations (faster) and decelerations (slower).

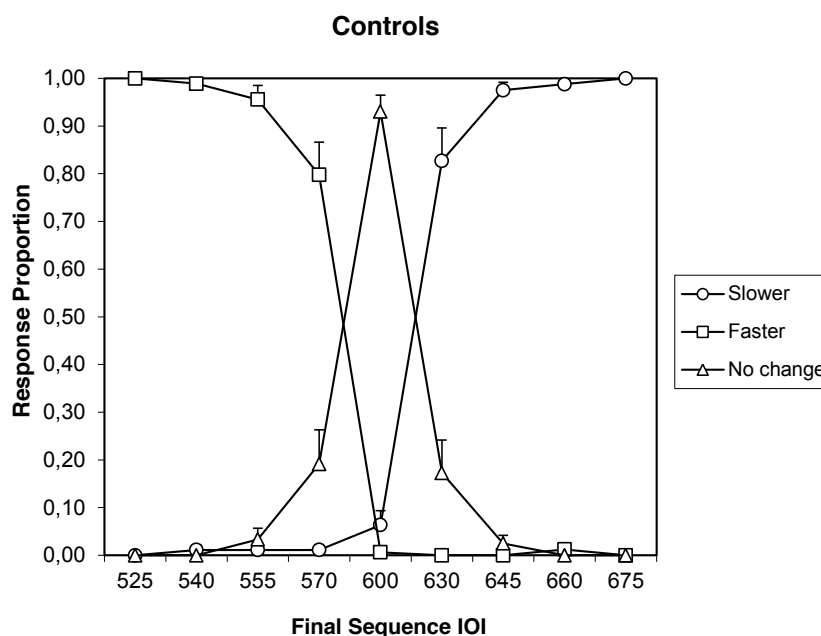
Separate 2 x 2 ANOVAs, with independent variables group (patients vs. controls) and tempo (faster vs. slower), were conducted for phase and period correction. The results indicated that period correction was generally more effective at faster tempi, Tempo  $F(1,16) = 8.14$ ,  $p < .02$ . However, the effects of tempo on period correction were different for patients and controls,

group x tempo  $F(1.16) = 9.625, p < .01$ . Patients engaged in less effective period correction at slower tempi than at faster tempi,  $F(1.8) = 14.52, p < .01$ , whereas such effects of tempo on period correction were absent in controls,  $F(1.8) = .40, p = .85$ .

### 3.3 Detection task

At the conclusion of each synchronization-continuation trial, participants were required to indicate orally whether the pacing sequence tempo had become faster, slower, or had remained constant. Average responses are shown for both groups in Fig. 7.





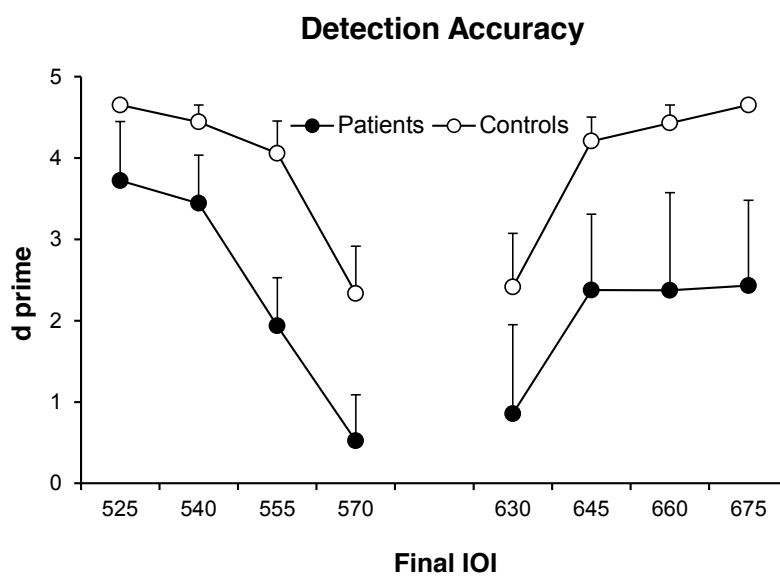
**Fig. 7.** Proportion of responses to tempo changes for basal ganglia patients and healthy controls. IOI = interonset interval.

The responses of all participants were converted into  $d'$  scores in order to take potential response biases into account (Fig. 8). These scores were computed by subtracting  $z$ -transformed false alarm rates (i.e., the proportion of “slower” or “no change” responses for tempo increases, and “faster” or “no change” responses for tempo decreases) from hit rates (“faster” responses for tempo increases, and “slower” responses for tempo decreases). In accordance with our hypotheses, patients seemed to be more accurate for tempo accelerations while their performance for decelerations reached a plateau at +45 ms. A  $2 \times 2 \times 4$  ANOVA on these scores tested for the effects of group (patients vs. controls), tempo (faster vs. slower), and magnitude (+/- 30, 45, 60, 75 ms). This ANOVA was computed for the whole sample of participants as the perceptual judgment did not involve any motor component.

A main effect of group was significant,  $F(1.18) = 5.01$ ,  $p < .04$ , which confirms that patients were generally less sensitive to the tempo changes than controls. The effect of



magnitude was significant,  $F(3.48) = 8.02, p < .01$  and greater for accelerations than for decelerations, tempo x magnitude  $F(3.48) = 21.64, p < .01$ . There was no significant three-way interaction. Only an additional post-hoc 2 x 2 ANOVA restricted to the perceptually most salient changes ( $\pm 75$  ms) that should easily draw attention yielded an interaction for group x tempo,  $F(1.18) = 5.45, p < .03$ .



**Fig. 8.** Accuracy in the detection of tempo change for basal ganglia patients and healthy controls.

#### 4. Discussion

The current study explored spontaneous motor tempo and sensorimotor synchronization in patients with focal BG lesions by means of two finger tapping tasks. Damage to the BG was associated with a more heterogeneous distribution of individual rates as well as more variable tapping during the SMT task. These results confirm that BG lesions have an effect on SMT in that they affect the ability to execute a steady sequence of periodic actions. Given the role of the

BG in attention-dependent temporal processing, higher variability may be caused by imprecise representations of temporal structure. Alternatively, it could be simply due to noisy motor implementation. However, it seems unlikely that this is also the reason for the more heterogeneous distribution of SMT rates. In general, patients performed well in both tapping tasks and did not report difficulties with tapping per se. This suggests, that the freely chosen SMT rates reflect a different process. In the absence of external cues, SMT has to rely on internally generated, temporally regular pacing information. Such internal pacemaker function most likely engages the pre-supplementary motor area (pre-SMA) and its connections to the BG. The pre-SMA contributes to the planning and initiation of simple and complex action sequences, including those required during speech production [37]. Pre-SMA recruitment is strongest when actions are freely chosen and are not guided by external signals [38, 39], with increased activation in early PD patients [40]. However, the pre-SMA is also involved in perceptual temporal processing [41, 42], indicating a function in production and perception. Hence, heterogeneous SMT rates and higher variability can be explained on a structural level by impaired processing of temporal structure in connections from the pre-SMA to the anterior striatum [43, 44], the site affected in most patients.

Patients demonstrated good overall performance during SMS, however, they tapped with relatively high variability and their error correction was affected. More specifically, attention-dependent period correction was less efficient in response to tempo decelerations. Again, higher variability may be due to noisy motor implementation, whereas the difference in error correction hints at another process. While any specific value such as the 600 ms tempo used in the current study is certainly too precise to dissociate short-range from longer-range temporal processing, tempo changes relative to this base tempo were sufficient to induce a distinct impairment in the patient group. The fact that period correction was affected supports the notion of specific attention-dependent mechanisms underlying SMS and temporal processing. This process may be modeled as entrainment of the timekeeper and/or attention oscillation by a pulse train [4]. Whereas phase correction would be sufficient to compensate for subliminal perturbations encoded by the pre-attentive temporal processing system, additional period correction would be needed to adapt if the period of the internal timekeeper has to be adjusted. In the absence of subdivisions, that is, in the context of 1:1 tapping [45], phase correction is assumed to reflect a lower-level process and to rest on times of occurrence or reference points, whereas period

correction is assumed to rest on intervals and to involve some form of memory for at least one preceding event. Based on EEG data, Praamstra et al. [46] localized period correction in the supplementary motor area (SMA). The finding of impaired period correction is thus in line with the proposed role of the BG in interval-based, longer range temporal processing and an ongoing evaluation of temporal structure in cortico-striato-thalamo-cortical circuits involving the pre-SMA.

The periodically spaced events of the pacing sequence promote stimulus-driven synchronization. However, if attention-dependent temporal processing is necessary to recognize temporal regularity, BG lesions could be responsible for an erratic evaluation of temporal structure and inaccurate predictions about upcoming events. In line with DAT, this should affect the ability to focus attention in time and to detect a tempo change. In other words, while the temporal structure of successive pacing events conveys regular temporal structure that is precisely encoded by the pre-attentive temporal processing system, its potentially facilitatory effect on synchronization is weakened by inefficient attention-dependent temporal processing. This relates to the difficulties of PD patients in processing rhythms with a beat structure [19] and evidence for difficulties in temporal preparation in contrast to intact encoding of temporal intervals [47]. Damage to the BG may affect the ability to evaluate the temporal relations between successive events, thereby compromising the use of this information to compare rhythms, to align motor behavior, or to allocate attention. The detection of a subsequent event may then be affected by both imprecise representation and evaluation of temporal structure on the one hand and inefficient allocation of attention in time on the other hand. This in turn may explain the difficulties that patients displayed in detecting the tempo changes embedded at a predictable position in the pacing sequences.

The results of the present study speak in favor of a function of the BG in SMS that is not restricted to motor control, but that extends to attention-dependent temporal processing. Temporal processing and the recognition of temporal regularity are crucial for anticipation, which in turn is necessary to temporally align actions to events in the environment. The additional finding of reduced perceptual sensitivity to tempo changes in BG patients points to a temporal processing network that is engaged in both production and perception. Together, attention-dependent temporal processing and resulting difficulties to exploit temporal structure in

stimulus-driven attending and adaptive motor control offer an explanation for the observed differences between patients with BG lesions and healthy controls.

Acknowledgements: The authors would like to thank Bruno H. Repp for helpful comments during the early stages of this work and Anika Stockert for support in the preparation of the clinical data.

## 5. References

- [1] Fuster JM. The prefrontal cortex – an update: time is of the essence. *Neuron*, 2001; 30, 319-333.
- [2] Repp BH. Sensorimotor synchronization: A review of the tapping literature. *Psychon B Rev*, 2005; 12: 969-992.
- [3] Witt ST, Laird AR, Meyerand ME. Functional neuroimaging correlates of finger-tapping task variations: An ALE meta-analysis. *Neuroimage*, 2008; 42: 343-356.
- [4] Pikovsky A, Rosenblum M, Kurths J. *Synchronization: A universal concept in nonlinear sciences*. Cambridge: Cambridge Universal Press, 2003, 8 pp; 62 pp.
- [5] Glass L. Synchronization and rhythmic processes in physiology. *Nature*, 2001; 410: 277-284.
- [6] Matell MS, Meck WH. Cortico-striatal circuits and interval timing: coincidence detection of oscillatory processes. *Cognitive Brain Res*, 2004; 21: 139-170.
- [7] Buhusi CV, Meck WH. What makes us tick? Functional and neural mechanisms of interval timing. *Nat Rev Neurosci*, 2005; 6: 755-765.
- [8] Mates J. A model of synchronization of motor acts to a stimulus sequence. I. Timing and error corrections. *Biol Cybern*, 1994; 70: 463-473.
- [9] Repp BH, Keller PE. Adaptation to tempo changes in sensorimotor synchronization: Effects of intention, attention, and awareness. *Q J Exp Psychol*, 2004; 57A : 499-521.
- [10] Lewis PA, and Miall RC. Distinct systems for automatic and cognitively controlled time measurement: evidence from neuroimaging. *Curr Opin Neurobiol*, 2003; 13: 250-255.

- 
- [11] Spencer RMC, Zelaznik HN, Diedrichsen J, Ivry RB. Disrupted timing of discontinuous but not continuous movements by cerebellar lesions. *Science*, 2003; 300: 1437-1439.
- [12] Ivry RB. The representation of temporal information in perception and motor control. *Curr Opin Neurobiol*, 1996; 6: 851-857.
- [13] Meck WH, Benson AM. Dissecting the brain's internal clock: How frontal-striatal circuitry keeps time and shifts attention. *Brain Cognition*, 2002; 48: 195-211.
- [14] Large EW, Jones MR. The dynamics of attending: How we track time-varying events. *Psychol Rev*, 1999; 106: 119-159.
- [15] Barnes R, Jones MR. Expectancy, attention, and time. *Cognitive Psychol*, 2000; 41: 254-311.
- [16] O'Boyle DJ, Freeman JS, Cody FWJ. The accuracy and precision of timing of self-paced, repetitive movements in subjects with Parkinson's disease. *Brain*, 1996; 119: 51-70.
- [17] Harrington DL, Haaland KY, Hermanowicz N. Temporal processing in the basal ganglia. *Neuropsychology*, 1998; 12: 3-12.
- [18] Pope PA, Praamstra P, Wing AM. Force and time control in the production of rhythmic movement sequences in Parkinson's disease. *Eur J Neurosci*, 2006; 23: 1643-1650.
- [19] Grahn JA, Brett M. Impairment of beat-based rhythm discrimination in Parkinson's disease. *Cortex*, 2009; 45: 54-61.
- [20] Merchant H, Luciana M, Hooper C, Majestic S, Tuite P. Interval timing and Parkinson's disease: heterogeneity in temporal performance. *Exp Brain Res*, 2008; 184: 233-248.
- [21] Diedrichsen J, Ivry RB, Pressing J. Cerebellar and basal ganglia contributions to interval timing. In: Meck WH, editor. *Functional and neural mechanisms of interval timing*. Boca Raton: CRC Press, 2003, 457-484.
- [22] Shin JC, Aparicio P, Ivry RB. Multidimensional sequence learning in patients with focal basal ganglia lesions. *Brain Cognition*, 2005; 58: 75-83.
- [23] Aparicio P, Diedrichsen J, Ivry RB. Effects of focal basal ganglia lesions on timing and force control. *Brain Cognition*, 2005; 58: 62-74.
- [24] Koch G, Oliveri M, Caltagirone C. Neural networks engaged in milliseconds and seconds time processing: evidence from transcranial magnetic stimulation and patients with cortical or subcortical dysfunction. *Phil Trans Soc B*, 2009; 364: 1907-1918.

- 
- [25] Buonomano DV. The biology of time across different scales. *Nat Chem Biol*, 2007; 3: 594-597.
- [26] Rammsayer TH. Neuropharmacological evidence for different timing systems in humans. *Q J Exp Psychol B*, 1999 ; 52: 273-286.
- [27] Lewis PA, Miall RC. Remembering the time: A continuous clock. *Trends Cogn Sci*, 2006; 10: 401-406.
- [28] Fraise P. Rhythm and tempo. In: Deutsch D, editor. *The psychology of music*. New York: Academic Press, 1982, 149-180.
- [29] Drake C, Jones MR, Baruch C. The development of rhythmic attending in auditory sequences: attunement, referent period, focal attending. *Cognition*, 2000; 77: 251-288.
- [30] McAuley JD, Jones MR, Holub S, Johnston HM, Miller NS. The time of our lives: Life span development of timing and event tracking. *J Exp Psychol*, 2006; 135: 348-367.
- [31] Fraise, P. *The psychology of time*. New York: Harper, 1963, 118 pp.
- [32] Parncutt R. A perceptual model of pulse salience and metrical accent in musical rhythms. *Music Percept*, 1994; 11: 409-464.
- [33] Drake C, Botte, MC. Tempo sensitivity in auditory sequences: evidence for a multiple-look model. *Percept Psychophys*, 1993; 54: 277-286.
- [34] London J. Cognitive constraints on metric systems: some observations and hypotheses. *Music Percept*, 2002; 19: 529-550.
- [35] Karmarkar UR, Buonomano DV. Timing in the absence of clocks: encoding time in neural network states. *Neuron*, 2007; 53: 427-438.
- [36] Aschersleben G. Temporal control of movements in sensorimotor synchronization. *Brain Cognition*, 2002; 48: 66-79.
- [37] Alario F, Chainay H, Lehericy S, Cohen L. The role of the supplementary motor area (SMA) in word production. *Brain Res*, 2006; 1076: 129-143.
- [38] Halsband U, Ito N, Tanji J, Freund H-J. The role of the premotor cortex and the supplementary motor area in the temporal control of movement in man. *Brain*, 1993; 116: 243-266.
- [39] Nachev P, Kennard C, Husain M. Functional role of the supplementary and pre-supplementary motor areas. *Nat Rev Neurosci*, 2008; 9: 856-869.

- 
- [40] Eckert T, Peschel T, Heinze H-J, Rotte M. Increased pre-SMA activation in early PD patients during simple self-initiated hand movements. *J Neurol*, 2006; 253: 199-207.
- [41] Coull JT, Vidal F, Nazarian B, Macar F. Functional anatomy of the attentional modulation of time estimation. *Science*, 2004; 303: 1506-1508.
- [42] Macar F, Coull J, Vidal F. The supplementary motor area in motor and perceptual time processing: fMRI studies. *Cogn Process*, 2006; 7: 89-94.
- [43] Lehericy S, Ducros M, Krainik A, Francois C, Van de Moortele P, Ugurbil K, Kim D. 3-D diffusion tensor axonal tracking shows distinct SMA and Pre-SMA projections to the human striatum. *Cereb Cortex*, 2004; 14: 1302-1309.
- [44] Johansen-Berg H, Behrens TEJ, Robson MD, Drobnyak I, Rushworth MFS, Brady JM, Mith SM, Higham DJ, Matthews PM. Changes in connectivity profiles define functionally distinct regions in human medial frontal cortex. *P Natl Acad Sci USA*, 2004; 101: 13335-13340.
- [45] Repp BH. Multiple temporal references in sensorimotor synchronization with metrical auditory sequences. *Psychol Res*, 2008; 72: 79-98.
- [46] Praamstra P, Turgeon M, Hesse CW, Wing AM, Perryer L. Neurophysiological correlates of error correction in sensorimotor-synchronization. *Neuroimage*, 2003; 20: 1283-1297.
- [47] Praamstra P, Pope P. Slow brain potential and oscillatory EEG manifestations of impaired temporal preparation in Parkinson's disease. *Journal of Neurophysiology*, 2007; 98: 2848-2857

## **Chapter 4**

### **Article II**

- 6. Temporal regularity effects on pre-attentive and attentive processing of deviance (*Biological Psychology*, 87 (2011), 146-151)**





**Temporal regularity effects on pre-attentive and attentive processing of deviance**

Michael Schwartz<sup>a\*</sup>, Kathrin Rothermich<sup>a</sup>, Maren Schmidt-Kassow<sup>b</sup> and Sonja A. Kotz<sup>a</sup>

<sup>a</sup>*Max Planck Institute for Human Cognitive and Brain Sciences  
Independent Research Group “Neurocognition of Rhythm in Communication”, Stephanstrasse 1a,  
04103 Leipzig, Germany*

<sup>b</sup>*Institute for Medical Psychology, Johann Wolfgang Goethe-Universität, Heinrich-Hoffmann-  
Strasse 10, 60528 Frankfurt am Main, Germany*

Corresponding author\*:

Michael Schwartz

Max Planck Institute for Human Cognitive and Brain Sciences

Research Group “Neurocognition of Rhythm in Communication”

Stephanstrasse 1a

04103 Leipzig

Germany

Tel: +49 341 99402473

Fax: +49 341 99402260

Email: [schwartz@pbs.mpg.de](mailto:schwartz@pbs.mpg.de)

Keywords: ERP, oddball, attention, timing, regularity

**Abstract**

Temporal regularity allows predicting the temporal locus of future information thereby potentially facilitating cognitive processing. We applied event-related brain potentials (ERPs) to investigate how temporal regularity impacts pre-attentive and attentive processing of deviance in the auditory modality. Participants listened to sequences of sinusoidal tones differing exclusively in pitch. The inter-stimulus interval (ISI) in these sequences was manipulated to convey either isochronous or random temporal structure. In the pre-attentive session, deviance processing was unaffected by the regularity manipulation as evidenced in three event-related-potentials (ERPs): mismatch negativity (MMN), P3a, and reorienting negativity (RON). In the attentive session, the P3b was smaller for deviant tones embedded in irregular temporal structure, while the N2b component remained unaffected. These findings confirm that temporal regularity can reinforce cognitive mechanisms associated with the attentive processing of deviance. Furthermore, they provide evidence for the dynamic allocation of attention in time and dissociable pre-attentive and attention-dependent temporal processing mechanisms.

## 1. Introduction

Continuous change is a fundamental characteristic of life. Changes generate temporal structure or events in time, with effective behavior depending in part on the temporal coherence of cognition, action, and these events. The key to temporal coherence is adequate timing, i.e., the ability to be in the right place at the right time. Timing and temporal organization are not only crucial in overt behavior but also in cognitive processes and the allocation of cognitive resources (Fuster, 2001). How do neurocognitive processes cope with the temporal structure of the environment to achieve adequate timing in cognition and action? Adequate timing implies some internal representation of temporal structure. It is unclear though whether temporal structure is processed implicitly, or whether an explicit representation of temporal structure is generated by dedicated temporal processing systems (Buonomano, 2007; Ivry and Schlerf 2008). Some neurofunctional models suggest that dedicated temporal processing is a function of classical motor systems of which the cerebellum is involved in pre-attentive, short-range, event-based temporal processing, and the basal ganglia are engaged in attention-dependent, longer-range, interval-based temporal processing (Ivry, 1996; Lewis and Miall, 2003; Spencer et al., 2003; Buhusi and Meck, 2005). A benefit that may arise from the explicit processing and the evaluation of temporal structure is to recognize and prospectively use temporal regularity. This would allow to predict the temporal locus of future events and to allocate attention towards important aspects of information. Expectations and prior knowledge about upcoming information should entail optimized timing in cognition and action even if the use of temporal structure is subconscious and unintentional, i.e., if temporal processing is exogenous (Nobre et al., 2007; Coull and Nobre, 2008).

The proposed dissociation of pre-attentive and attention-dependent temporal processing systems offers a starting point to further characterize the underlying processes. In this context, important issues concern (1) the moment at which attention affects temporal processing, (2) whether temporal structure can be processed without adopting strategies for estimating time (Grondin, 2001), and (3) how attention is allocated and maintained in the presence of acoustic, and hence inherently temporal, signals. Early on, Bolton (1894) emphasized that attention appears discontinuous and intermittent, and that it manifests in a wave-like form or a series of pulses. Consequently, some form of adaptation deems necessary to align the internal fluctuation

of the attentional focus with the temporal structure of external events. With respect to the auditory domain, one important aspect in this interplay could be the bias of the auditory system to search for regularities in sensory input (Winkler et al., 2009). Although continuously changing, the temporal structure of the environment is not arbitrary. Any perceived regularity in temporal structure can indicate a pattern. Temporal patterns emerge in both the environment and in the allocation of attention (Jones and Boltz, 1989). This transient temporal stability in combination with predictive processing is fundamental for optimal anticipatory timing in cognition and action. This notion is expressed in Dynamic Attending Theory (DAT; Jones and Boltz 1989; Large and Jones, 1999). DAT proposes that internal attending rhythms synchronize with external event structure. This mechanism may be relevant to dissociate pre-attentive from attention-dependent temporal processing mechanisms. Ongoing processing of relatively stable temporal relations instantiates a repetitive process which can be conceived of as an instance of oscillatory activity. Oscillatory activity and interactions between different oscillations caused by appropriate external or internal stimulation constitute another fundamental characteristic of life (Glass, 2001). Their interplay represents an inherent property of both, living things and the activity of attending (Jones and Boltz, 1989). As such, oscillatory mechanisms provide a realistic computational basis to model the “adaptation to change by anticipation” (Fraisse, 1963, pp. 18). DAT proposes that one or more attention oscillations entrain to the rate and rhythm of external events (Large and Jones, 1999), i.e., adaptive oscillations lock into the temporal structure of the stimulation, thereby establishing synchronized processing. If confronted with a change in temporal structure, the oscillations adjust their phase and period in order to maintain or to reestablish synchronization. The result of this process is stimulus-driven attending (Barnes and Jones, 2000). DAT provides a framework capable of explaining how temporal structure guides attention on a moment-to-moment basis and temporal dependencies within a pattern, i.e. the possible influence of preceding temporal structure on subsequent temporal processing, and the influence of global temporal context (McAuley and Miller, 2007).

In the current study we used ERPs to investigate the impact of regular and irregular temporal structure on the pre-attentive and attentive processing of change by means of auditory oddball sequences. An oddball sequence consists of more (standard) and less (deviant) frequent events, with the deviant event violating some rule established by the standard. Pre-attentive and attentive processing of this deviation is associated with distinct sets of endogenous ERPs. With

respect to the former we focus on mismatch negativity (MMN), P3a, and reorienting negativity (RON), and with respect to the latter on N2b and P3b.

In combination, MMN, P3a, and RON form the “distraction potential” (Escera and Corral, 2007). The MMN has a fronto-central scalp distribution and is elicited in response to a discriminable change in auditory stimulation compared to a repetitive aspect of preceding stimuli retained in short-term memory (Näätänen et al., 1978; Näätänen, 2007; Garrido et al., 2009). Usually the MMN peaks around 100 to 200 ms after the presentation of the deviant event. It reflects pre-attentive processing of sensory information as events in time, including auditory duration discrimination (Näätänen et al., 2004; Näätänen, 2007). The term MMN has largely replaced the classification of this component as a subcomponent of the N2 under the N2a label (Folstein and van Petten, 2008). The P3a is a fronto-centrally distributed positive deflection evoked by task-irrelevant salient events (Linden, 2005), whereas the later fronto-central RON reflects restoration of the task-optimal selective attention set following distraction by task-irrelevant events (Schröger and Wolff, 1998). However, although these components are related to the processing of deviant changes in the environment they can be elicited independent of each other (Horváth et al., 2008).

With respect to attention-dependent processing we concentrate on another fronto-central N2 subcomponent, the N2b, associated with the attentive detection of a deviant event, and the P3b, which typically peaks around 300 ms after the presentation of a deviant event. Like the P3a, the more centro-parietal P3b is part of the P300 complex (Polich and Criado, 2006; Volpe et al., 2007). However, each P3a is accompanied by a smaller P3b and vice versa (Linden, 2005). The P3b is commonly related to a task-relevant alteration of a mental model of the environment, a stimulus-driven attention mechanism, and memory processing (Linden, 2005; Polich, 2007). The goal of the current study was to investigate how the contrast between regular, and therefore highly predictable temporal structure, and irregular temporal structure would modulate the aforementioned ERP components associated with various aspects of the processing of deviance. In line with DAT, regular temporal structure was expected to narrow the attentional focus and to promote synchronization, whereas irregular structure should widen the attentional focus and promote reactive attending (Jones et al., 2002). We consider the ERP modulation as an index for the quality of stimulus-driven synchronization, the dynamic allocation of attention, and the quality of cognitive processes associated with the processing of deviant events. Specifically, we

hypothesize that attention-dependent recognition of temporal regularity and the subsequent use of this information to predict upcoming events results in an enhanced amplitude of the N2b and P3b components in response to deviants embedded in regular temporal structure relative to those embedded in irregular temporal structure. This enhancement should be similar for the pre-attentive processing of change, and the distraction potential, i.e., MMN, P3a, and RON, only if the underlying mechanism is also sensitive to temporal regularity. Alternatively, if attention-dependent temporal processing is necessary to exploit regularity, pre-attentive temporal processing should not benefit from temporal regularity. In this case the distraction potential should be resistant against the manipulation.

## **2. Materials and Methods**

### **2.1 Participants**

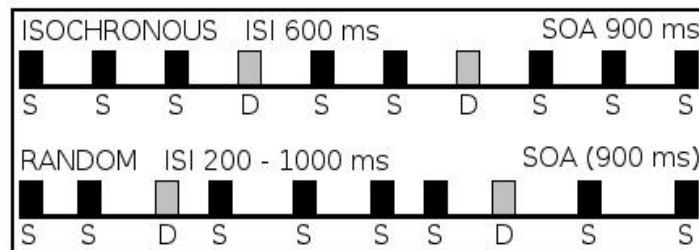
Twenty-four right-handed volunteers (12 females) participated in the study. Ages ranged from 19 to 30 years (mean: 24.4; SD: 2.8 years). All participants were students at the University of Leipzig and were recruited via the database of the Max-Planck Institute for Human Cognitive and Brain Sciences in Leipzig. None of the participants reported any neurological dysfunction or a hearing deficit at the time of testing. All participants gave their written informed consent and received a compensatory fee. The study was approved by the ethics committee of the University of Leipzig.

### **2.2 Stimulus presentation, EEG recording, and ERP analysis**

The stimulus material consisted of two equidurational (300 ms; 10 ms rise and fall) sinusoidal tones. The tones were used to generate a temporally regular, i.e. isochronous, and a temporally irregular, i.e. random, auditory oddball sequence. The latter was created by varying the duration

of the inter-stimulus-interval (ISI) between individual tones. Whereas the ISI was 600 ms in the isochronous sequence, it was randomly assigned from a range between 200 and 1000 ms (normally distributed around an average 600 ms) in the random sequence. These specific parameters were chosen in order to take into consideration the privileged status of simple integer ratios and intervals lasting about 600 ms (Fraisse, 1982; Essens, 1986; Martin et al., 2007). An average SOA of 900 ms is still within the range of optimal tempo sensitivity (Drake and Botte, 1993), as well as the synchronization range (Fraisse, 1982). Thus, stimulus, ISI, and SOA intervals ranged from 300 to 1000 ms. The boundary between short-range and attention-dependent longer-range temporal processing mechanisms is commonly associated with values close to 1000 ms (Buhusi and Meck, 2005; Lewis and Miall, 2006). However, the mechanism underlying attention-dependent temporal processing is probably sensitive to intervals ranging from hundreds of milliseconds to seconds (Meck et al., 2008).

The two tones differed in frequency (600 Hz for standards, and 660 Hz for deviants (Fig 1)). Each oddball sequence comprised 512 standard and 128 deviant tones, corresponding to a total of 640 tones and a standard-to-deviant ratio of 4:1.



**Fig.1.** Stimulus sequences. Exemplary sections of isochronous and random stimulus sequences consisting of standard (S) and deviant (D) sinusoidal tones. SOA = stimulus onset asynchrony. The figure in parentheses indicates the global average across the random sequence.

Presentation 12.0 (Neurobehavioral Systems) running on a Windows PC was used to create the pseudorandomized oddball sequence and to present the stimuli via two loudspeakers. Pseudorandomization ensured that no more than two deviant events could appear in a row. The 600 ms ISI in the isochronous sequence resulted in a 1:2 ratio for the duration of the filled stimulus intervals and the empty ISI intervals. The order of these sequences was pseudo-



randomized across participants. After the presentation of the first sequence, participants were given a 5 min. break. The experiment was split into two sessions on two consecutive days. All participants started with the pre-attentive session followed by the attentive session to preclude familiarity effects.

The EEG procedure was identical in both sessions. During the EEG recording participants sat in a sound-attenuated booth in front of a monitor. Ag/AgCl electrodes mounted in an elastic cap according to the 10-20 International system were used to record the EEG from 59 scalp sites with a sampling rate of 500 Hz. An anti-aliasing filter of 135 Hz was applied. Online reference was placed on the left mastoid and the sternum served as ground. Besides the EEG, horizontal and vertical electrooculography were recorded. Electrode impedance was kept below 5 k $\Omega$ . EEP 3.2 (Max-Planck Institute for Human Cognitive and Brain Sciences, Leipzig, Germany) was used to process the data. All data were re-referenced offline to averaged mastoids. Prior to subsequent analyses, EEG epochs lasting from 100 ms pre-stimulus onset to 450 ms post-stimulus onset were scanned by an automatic algorithm to reject eye movements, blinks, muscle artifacts, and electrode drifting. Trials exceeding 30  $\mu$ V (eye channels) or 40  $\mu$ V (CZ) were rejected. An additional manual rejection of trials containing artifacts or electrode drifting was performed after visual inspection. All epochs of events corresponding to the presentation of a standard after a deviant as well as a deviant following another deviant were generally rejected. Remaining epochs were averaged for each participant and for the whole group.

Statistical analyses were performed using SAS 8.20.20 (SAS Institute Inc., Cary, USA) for subsets of electrodes in six regions of interest. These regions included left-anterior (AF7, AF3, F9, F7, F5, F3), left-central (T7, C5, C3, TP7, CP5, CP3), left-posterior (P7, P5, P3, PO7, PO3, O1), right-anterior (AF8, AF4, F10, F8, F6, F4), right-central (T8, C6, C4, TP8, CP6, CP4), and right-posterior (P8, P6, P4, PO8, PO4, O2) electrode sites. Based on visual inspection and preparatory timeline analyses on mean amplitudes for consecutive windows of 25 ms from stimulus onset up to 450 ms post-stimulus onset, 100 – 200 ms MMN, 225 – 325 ms P3a, and 325 – 450 ms RON windows were selected for the subsequent statistical main analyses for the pre-attentive session, while 125 – 225 ms N2b and 250 – 450 ms P3b windows were selected for the attentive session. Timeline analyses consisted of separate 2 x 2 x 2 x 3 ANOVAs with factors type (isochronous vs. random), condition (standard vs. deviant), hemisphere (left vs. right) and region (anterior vs. central vs. parietal) for each 25 ms window.

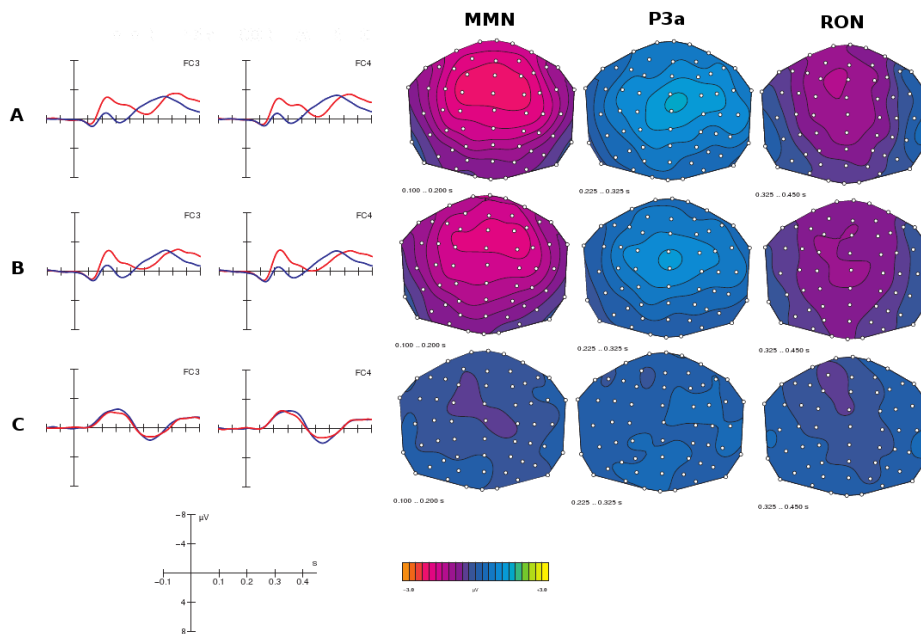
## **2.3 Tasks**

In the pre-attentive session, participants were asked to watch a silent video clip (Deep Blue, 2003) and to fill out a short questionnaire about the video after the session. Prior to testing, participants were told that they should concentrate on the video and to ignore any auditory input. In contrast, participants were asked to concentrate on the tonal sequences and to silently count the deviants embedded in each sequence while fixating an asterisk displayed on the monitor during the attentive session. Participants reported the result of counting after each sequence. Thus, while the sequences themselves were attended to, explicit attention to temporal structure was not task-relevant. Rather, temporal structure served as an implicit attractor for attention-dependent temporal processing. An additional sequence of eight tones, including five deviants, was appended to each random sequence in order to avoid identical numbers of deviants in each sequence. These additional tone sequences were excluded from all ERP analyses.

## **3. Results**

### **3.1 Pre-attentive session**

The percentage of correct answers given in the questionnaire after the pre-attentive session was 84.38 (SD 16.17), indicating that participants did indeed pay attention to the content of the video clip. Both isochronous and random oddball sequences evoked reliable MMN, P3a, and RON ERPs (Fig. 2 A and B).



**Fig 2.** Pre-attentive session. Averaged EEG responses for standards (blue) and deviants (red) at two fronto-central electrodes in the pre-attentive session complemented by MMN, P3a, and RON scalp distributions for isochronous (A) and random (B) temporal structure. Differences waves and difference distributions contrast ERP effects for isochronous (blue) and random (red) temporal structure (C).

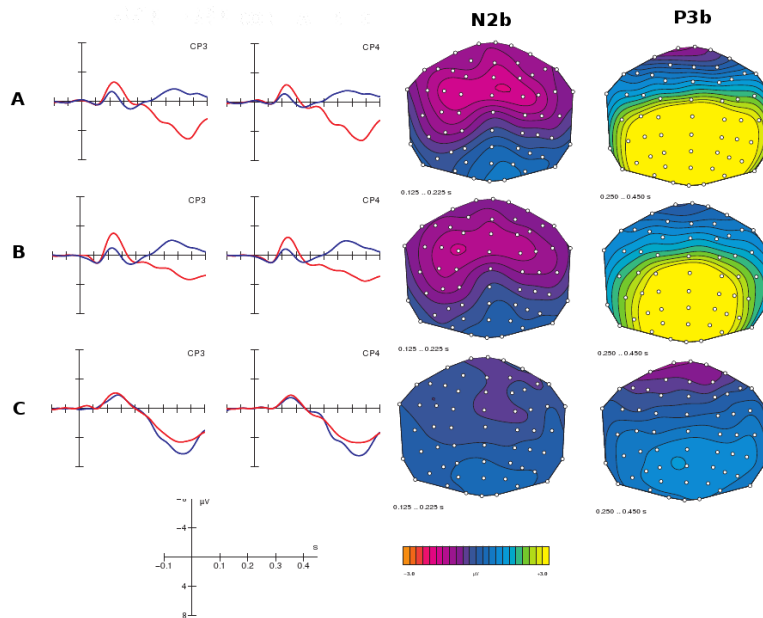
To ensure that each sequence elicited the desired components, all ERPs of interest were analyzed in separate  $2 \times 2 \times 3$  ANOVAs with the factors condition (standard vs. deviant), hemisphere (left vs. right), and region (anterior vs. central vs. posterior). Where required, Greenhouse-Geisser correction was applied to the results reported in the following. In the isochronous sequences, there was a main effect of condition in the MMN ( $F(1,23) = 53.51, p < .01$ ), the P3a ( $F(1,23) = 10.20, p < .01$ ), and the RON ( $F(1,23) = 6.12, p < .03$ ) time-window. In the MMN time-window we observed a significant two-way interaction of condition and region ( $F(2,46) = 14.22, p < .01$ ), indicating that the condition effect was strongest at anterior sites ( $F(1,23) = 60.76, p < .01$ ). In the random sequences we observed a similar pattern for condition in the MMN ( $F(1,23) = 55.52, p < .01$ ), the P3a ( $F(1,23) = 6.34, p < .02$ ), and the RON ( $F(1,23) = 13.19, p < .01$ ) time-window. Again, there was a significant interaction in the MMN window of condition and region

( $F(2,46) = 14.22, p < .01$ ), revealing that the effect was strongest at anterior sites ( $F(1,23) = 49.40, p < .01$ ).

For the direct comparison of the effects obtained with isochronous and random temporal structure, we calculated difference waves by subtracting standard from deviant ERP responses. All subsequent analyses were performed on these difference waves. In contrast to random temporal structure, visual inspection suggested slightly more negative and positive effects as a function of isochronous temporal structure for the MMN and the P3a, respectively (Fig. 2 C). However, contrasting the effects by means of  $2 \times 2 \times 2$  ANOVAs with factors type (isochronous vs. random), hemisphere (left vs. right), and region (anterior vs. central vs. posterior) only conformed an effect of region ( $F(2,46) = 15.23, p < .01$ ), but not of type ( $F(1,23) = .31, p = .58$ ) and no significant interaction. To further validate this finding, we narrowed the critical time window down to 50 ms and centered it in the optimal range (125 – 175 ms). However, this procedure did not change the initial result, type ( $F(1,23) = 1.37, p = .25$ ). The same type of ANOVA was conducted for the P3a and the RON time-window, none of which yielded significant results. Narrowing the critical range for the P3a time-window to 250 – 300 ms did not change this outcome. Thus, we did not observe a significant influence of temporal regularity on the cognitive mechanisms underlying the pre-attentive processing of the deviant events.

### **3.2 Attentive session**

One-sample t-tests yielded no significant differences between the individual values reported by the participants in the counting task and the actual number of deviants embedded in the isochronous (actual number: 128; mean result: 128.21, SD: 4.35;  $t(1,23) = .23, p = .81$ ) and in the random (actual number: 133; mean result: 133.25, SD: 4.48;  $t(1,23) = .27, p = .79$ ) sequence. These results confirmed that participants indeed paid attention to the tonal sequences. The same type of  $2 \times 2 \times 3$  ANOVA as for the pre-attentive session was conducted to test for the presence of the ERPs of interest in the attentive session (Fig. 3 A and B).



**Fig 3.** Attentive session. Averaged EEG responses for standards (blue) and deviants (red) at two centro-parietal electrodes in the attentive session complemented by N2b and P3b scalp distributions for isochronous (A) and random (B) temporal structure. Differences waves and difference distributions contrast ERP effects for isochronous (blue) and random (red) temporal structure (C).

Both the isochronous and the random oddball sequence elicited significant N2b and P3b components. In the N2b time-window we obtained significant effects of condition in the isochronous ( $F(1,23) = 4.29, p < .05$ ) and in the random ( $F(1,23) = 6.32, p < .02$ ) sequence. In both sequence types interactions of condition and region ( $F(2,46) = 14.90, p < .01$ ;  $F(2,46) = 13.14, p < .01$ ) indicated that the effect was present at anterior ( $F(1,23) = 7.17, p < .02$ ;  $F(1,23) = 8.75, p < .01$ ) and at central sites ( $F(1,23) = 8.80, p < .01$ ;  $F(1,23) = 12.26, p < .01$ ). The effect of condition emerged also in the P3b window in isochronous ( $F(1,23) = 58.14, p < .01$ ) and random sequences ( $F(1,23) = 42.77, p < .01$ ). An interaction of the factors condition and region in both sequences ( $F(2,46) = 79.10, p < .01$ ;  $F(2,46) = 63.48, p < .01$ ) indicated that the effect of condition was present at central sites ( $F(1,23) = 78.77, p < .01$ ;  $F(1,23) = 48.35, p < .01$ ), but that it was stronger at posterior sites for isochronous ( $F(1,23) = 98.07, p < .01$ ) and random sequences ( $F(1,23) = 67.17, p < .01$ ).

Again, difference waves were calculated for the subsequent comparison of the isochronous and the random sequence. In the N2b time-window, direct comparison of the ERP effects obtained with isochronous and random stimulation (Fig. 3 C) yielded neither a significant effect of type ( $F(1,23) = .38, p = .55$ ) nor a significant interaction involving this factor. Narrowing the critical window to 175 – 225 ms did not change this result, type ( $F(1,23) = .08, p = .78$ ).

While the main effect of type was not significant in the P3b time-window ( $F(1,23) = 1.92, p = .18$ ), there was a significant interaction of type and region ( $F(2,46) = 7.94, p < .01$ ). Type approached significance at central sites ( $F(1,23) = 3.99, p = .058$ ), but was significant at posterior sites ( $F(1,23) = 4.76, p < .04$ ) confirming a larger P3b effect in isochronous than in random sequences.

#### 4. Discussion

In the current study we investigated the impact of temporal regularity on ERPs associated with pre-attentive and attentive processing of auditory deviant events. The applied experimental paradigms reliably elicited MMN, P3a, RON, N2b, and P3b components. Regular temporal structure resulted in a larger attention-dependent P3b effect relative to irregular temporal structure. The results support the dissociation of pre-attentive and attention-dependent temporal processing mechanisms. Furthermore, they confirm concepts of a dynamic allocation of attention put forward in DAT (Large and Jones, 1999).

In the pre-attentive session, we did not observe a substantial impact of temporal regularity on three ERP components reflecting different aspects of deviant event processing. Unlike previous studies which used a limited number of SOAs (two or three) and report an effect of temporal regularity on MMN amplitude (Imada et al., 1993; Takegata and Morotomi, 1999; Moberget et al., 2008), the current study used online randomization, i.e. no predefined set of SOAs, to generate irregular temporal structure. Takegata and Morotomi (1999) conclude that increasing the number of SOAs in a sequence, not irregular timing, is the reason for the observed influence, as different SOAs may strengthen different memory traces. This hints at a qualitative difference between previous studies and the current study. Whereas continuous presentation of many stimulus repetitions with a limited number of predefined and well distinguishable SOAs

may evoke different, albeit weaker, memory traces, online randomization in the current study was only limited by temporal range, which in turn may prove temporal structure unreliable and dispensable. Crucially, in this latter case successive stimuli may still strengthen the same memory trace. However, even the random sequence conveys some regularity, as the sequential presentation of similar events in a specific time-window constitutes a form of regularity in itself. Thus, the question arises, how repetitive presentation of predefined temporal structure (“the SOA is either short or long”) compares to relative temporal structure (“the SOA is 900 ms on average”) in generating a random sequence, and how this difference affects deviance processing. With independently varied ISIs and SOAs, Takegata et al. (2001) found a larger MMN for constant temporal structure in comparison to either constant ISI, constant SOA, or neither constant conditions, but no difference between the latter. However, deviant events in this study were tones being presented “too early”, thereby merging temporal structure and deviance levels. By using frequency deviants we separated deviance from temporal structure. Nevertheless, for the MMN and the P3a, but not the RON, visual inspection suggested slightly more pronounced effects for deviants embedded in the isochronous sequence. However, this difference was not statistically significant. Morphological differences and the presence of a significant RON for regular and irregular contexts may indicate short episodes of attention-dependent temporal processing in the pre-attentive session following distraction by a task-irrelevant deviant event. Correspondingly, one can not completely rule out episodes of divided attention between the tonal stimuli and the silent video clip. Yet, processing of the deviant events in the pre-attentive session was neither significantly facilitated nor hindered by the temporal manipulation employed in this study. When contrasted with the results from the attentive session, this indifference bears implications for temporal processing and the allocation of attentional resources. When task instructions required to not attend to the auditory stimuli, an internal representation of temporal structure may still be encoded via pre-attentive temporal processing. Correspondingly, we did not find an indication of stimulus-driven synchronization in the pre-attentive session. Decoding of such internal representation of temporal structure and the recognition of temporal regularity likely require additional attention-dependent temporal processing routines such as duration discrimination of successive intervals (Meck et al., 2008). Once a pattern has been recognized, subsequent processing should be facilitated as it allows predicting the temporal locus of future events, to focus attention on specific information, and to initiate behavior anticipatorily.

During the early stages of auditory processing it is probably more relevant to rapidly detect events and to generate precise internal representations of temporal structure. This may be necessary to encode temporal detail before this information becomes erratic due to long neural transmission lines and numerous synapses (Adams, 2006). This function may involve the cerebellar temporal processing system and its connections to the earliest stages of auditory processing (Petacchi et al., 2005). The auditory cortex may keep reference to the immediate auditory past and future (Näätänen et al., 2001), probably processing temporal regularity without depending on it. This would explain the robustness of the pre-attentive ERPs against the temporal manipulation. Furthermore, given that temporal irregularity or deviation from a temporal pattern may represent important information in itself, the initial processing should be comparable, independent of whether the input indeed conveys regularity or whether it is irregular. In contrast, we observed an influence of temporal regularity in the attentive session. Whereas the earlier N2b effect remained unaffected, the later P3b effect was significantly larger for deviant events embedded in isochronous context. In line with DAT, this may reflect stimulus-driven synchronization of attention that leads to facilitation in cognitive processing. Furthermore, this dissociation hints at a difference in the time-course of the underlying processes. With respect to the moment at which attention affects temporal processing, these results speak for an impact of attention on later mechanisms relative to those represented in the earlier N2b. The influence of attention-dependent temporal processing is hence not reflected in the detection of deviant events. It becomes apparent in subsequent memory processing and model updating, possibly referring to successful memory storage in order to facilitate retrieval and recognition (Polich, 2007). These processes may involve the ongoing evaluation of an interval-based representation of temporal inter-event relations in order to track regularity. Interestingly, the cortical generators of the P3b include the temporo-parietal junction and the inferior parietal lobe (Linden, 2005), an area that is also associated with implicit temporal processing (Coull and Nobre, 2008; Wiener et al., 2010). Furthermore, at this stage, temporal and memory processing may draw upon the same prefrontal capacities (Lustig et al., 2005; Lewis and Miall, 2006).

The observed influence of temporal regularity in the attentive session was independent of explicit attention to time or an explicit estimation of time. As long as attention was directed towards the auditory stimuli, temporal structure was processed and exploited without estimating time. The current results thereby offer an example for the interplay of top-down, task-specific



attention and stimulus-driven attending in order to guide attention along a sequential stimulation. In line with previous findings (Schmidt-Kassow et al., 2009) the P3b should hence be considered as an index for the quality of stimulus-driven synchronization. The specific pattern of results suggests that the attentive detection of a deviant event functions independent of temporal regularity, whereas subsequent processes benefit from temporal predictability of the stimulus sequence. We were able to show that temporally regular stimulus presentation (the “when” aspect of sensory input) supports the attentive processing of formal stimulus characteristics (the “what” aspect of sensory input). Although the current experiment restricted the formal aspect to a single difference in pitch, we expect this principle to be effective in other modalities and in complex settings such as music and speech processing (Kotz and Schwartz, 2010). This in turn may hint at a predisposition for constant attempts to synchronize cognition and action to perceived regularity in the succession of changes in the environment.

## 5. References

- Adams, J.C., 2006. Neuroanatomical considerations of speech processing. In S. Greenberg, W. Ainsworth (Eds.). *Listening to speech: an auditory perspective* (pp 79 – 90). Lawrence Erlbaum Associates, Mahwah.
- Barnes, R., Jones, M.R., 2000. Expectancy, attention, and time. *Cognitive Psychology* 41, 254-311.
- Bolton, T.L., 1894. Rhythm. *Journal of Psychology* 6, 145-238.
- Buhusi, C.V., Meck, W.H., 2005. What makes us tick? Functional and neural mechanisms of interval timing. *Nature Reviews Neuroscience* 6, 755-765.
- Buonomano, D.V., 2007. The biology of time across different scales. *Nature Chemical Biology* 3, 594-597.
- Coull, J.T., Nobre, A.C., 2008. Dissociating explicit timing from temporal expectation with fMRI. *Current Opinion in Neurobiology* 18, 137-144.
- Drake, C., Botte, M.C., 1993. Tempo sensitivity in auditory sequences: evidence for a multiple-look model. *Perception & Psychophysics* 54, 277-286.

- Escera, C., Corral, M.J., 2007. Role of mismatch negativity and novelty-P3 in involuntary auditory attention. *Journal of Psychophysiology* 21, 251-264.
- Essens, P.J., 1986. Hierarchical organization of temporal patterns. *Perception & Psychophysics* 40, 69 – 73.
- Folstein, J.R., van Petten, C., 2008. Influence of cognitive control and mismatch on the N2 component of the ERP: a review. *Psychophysiology* 45, 152-170.
- Fraisse, P., 1982. Rhythm and tempo. In D. Deutsch (Ed.). *The psychology of music* (pp. 149 – 180). Academic Press, New York.
- Fraisse, P., 1963. *The psychology of time*. Harper & Row, New York.
- Fuster, J.M., 2001. The prefrontal cortex – an update: time is of the essence. *Neuron* 30, 319-333.
- Garrido, M.I., Kilner, J.M., Stephan, K.E., Friston, K.J., 2009. The mismatch negativity: a review of underlying mechanisms. *Clinical Neurophysiology* 120, 453-463.
- Glass, L., 2001. Synchronization and rhythmic processes in physiology. *Nature* 410, 277-284.
- Grondin, S., 2001. From physical time to the first and second moments of psychological time. *Psychological Bulletin* 127, 22-44.
- Horváth, J., Winkler, I., Bendixen, A., 2008. Do N1/MMN, P3a, and RON form a strongly coupled chain reflecting the three stages of auditory distraction? *Biological Psychology* 79, 139-147.
- Imada, T., Loveless, H.N., McEvoy, L., Sams, M., 1993. Determinants of the auditory mismatch response. *Electroencephalography and Clinical Neurophysiology* 87, 144-153.
- Ivry, R.B., 1996. The representation of temporal information in perception and motor control. *Current Opinion in Neurobiology* 6, 851-857.
- Ivry, R.B., Schlerf, J.E., 2008. Dedicated and intrinsic models of time perception. *Trends in Cognitive Sciences* 12, 273-280.
- Jones, M.R., Boltz, M., 1989. Dynamic attending and responses to time. *Psychological Review* 96, 459-491.
- Jones, M.R., Moynihan, H., MacKenzie, N., Puente, J., 2002. Temporal aspects of stimulus-driven attending in dynamic arrays. *Psychological Science* 13, 313-319.
- Kotz, S.A., Schwartz, M., 2010. Cortical speech processing unplugged: a timely subcortico-cortical framework. *Trends in Cognitive Sciences* 14, 392-399.

- Large, E.W., Jones, M.R., 1999. The dynamics of attending: how people track time-varying events. *Psychological Review* 106, 119-159.
- Lewis, P.A., Miall, R.C., 2003. Distinct systems for automatic and cognitively controlled time measurement: evidence from neuroimaging. *Current Opinion in Neurobiology* 13, 250-255.
- Lewis, P.A., Miall, R.C., 2006. Remembering the time: a continuous clock. *Trends in Cognitive Sciences* 10, 401-406.
- Linden, D.E.J., 2005. The P300: where in the brain is it produced and what does it tell us? *The Neuroscientist* 11, 563-576.
- Lustig, C., Matell, M.S., Meck, W.H. Not “just” a coincidence: frontal-striatal interactions in working memory and interval timing. *Memory* 13, 441-448.
- Martin, X.P., Delterne, P., Hoonhorst, I., Markessis, E., Rossion, B., Colin, C., 2007. Perceptual biases for rhythm: the mismatch negativity latency indexes the privileged status of binary vs non-binary interval ratios. *Clinical Neuropsychology* 118, 2709-2715.
- McAuley, J.D., Miller, N.S., 2007. Picking up the pace: effects of global temporal context on sensitivity to the tempo of auditory sequences. *Perception & Psychophysics* 69, 709-718.
- Meck, W.H., Penney, T.B., Pouthas, V., 2008. Cortico-striatal representation of time in animals and humans. *Current Opinion in Neurobiology* 18, 145-152.
- Moberget, T., Karns, C.M., Deouell, L.Y., Lindgren, M., Knight, R.T., Ivry, R.B., 2008. Detecting violations of sensory expectancies following cerebellar degeneration: a mismatch negativity study. *Neuropsychologia* 46, 2569-2579.
- Näätänen, R., Gaillard, A.W.K., Mäntysalo, S., 1978. Early selective-attention effect on evoked potential reinterpreted. *Acta Psychologica* 42, 313-329.
- Näätänen, R., Tervaniemi, M., Sussmann, E., Paavilainen, P., Winkler, I., 2001. ‘Primitive intelligence’ in the auditory cortex. *Trends in Neurosciences* 24, 283-288.
- Näätänen, R., Syssoeva, O., Takegata, R., 2004. Automatic time perception in the human brain for intervals ranging from milliseconds to seconds. *Psychophysiology* 41, 660-663.
- Näätänen, R., Paavilainen, P., Rinne, T., Alho, K., 2007. The mismatch negativity (MMN) in basic research of central auditory processing: a review. *Clinical Neurophysiology* 118, 2544-2590.

- Nobre, A.C., Correa, A., Coull, J.T., 2007. The hazards of time. *Current Opinion in Neurobiology* 17, 465-470.
- Petacchi, A., Laird, A.R., Fox, P.T., Bower, J.M., 2005. Cerebellum and auditory function: an ALE meta-analysis of functional neuroimaging studies. *Human Brain Mapping* 25, 118-128.
- Polich, J., Criado, J.R., 2006. Neuropsychology and neuropharmacology of P3a and P3b. *International Journal of Psychophysiology* 60, 172-185.
- Polich, J., 2007. Updating P300: an integrative theory of P3a and P3b. *Clinical Neurophysiology* 118, 2128-2148.
- Schröger, E., Wolff, C., 1998. Attentional orienting and reorienting is indicated by human event-related brain potentials. *Neuroreport* 9, 3355-3358.
- Schmidt-Kassow, M., Schubotz, R.I., Kotz, S.A., 2009. Attention and entrainment: P3b varies as a function of temporal predictability. *Neuroreport* 20, 31-36.
- Spencer, R.M.C., Zelaznik, H.N., Diedrichsen, J., Ivry, R.B., 2003. Disrupted timing of discontinuous but not continuous movements by cerebellar lesions. *Science* 300, 1437-1439.
- Takegata, R., Morotomi, T., 1999. Integrated neural representation of sound and temporal features in human auditory sensory memory: an event-related potential study. *Neuroscience Letters* 274, 207-210.
- Takegata, R., Syssoeva, O., Winkler, I., Paavilainen, P., Näätänen, R., 2001. Common neural mechanism for processing onset-to-onset intervals and silent gaps in sound sequences. *Neuroreport* 12, 1783-1787.
- Volpe, U., Mucci, A., Bucci, P., Merlotti, E., Galderisi, S., Maj, M., 2007. The cortical generators of P3a and P3b: a LORETA study. *Brain Research Bulletin* 73, 220-230.
- Wiener, M., Turkeltaub, P.E., Coslett, H.B., 2010. Implicit timing activates the left inferior parietal cortex. *Neuropsychologia* 48, 3967-3971.
- Winkler, I., Denham, S.L., Nelken, I., 2009. Modeling the auditory scene: predictive regularity representations and perceptual objects. *Trends in Cognitive Sciences* 13, 532-540.



## **Chapter 5**

### **Article III**

**7. Functional dissociation of pre-SMA and SMA-proper in temporal processing (Neuroimage, 60 (2012), 290-298)**



**Functional dissociation of pre-SMA and SMA-proper in temporal processing**

Michael Schwartz \* , Kathrin Rothermich and Sonja A. Kotz

*Max Planck Institute for Human Cognitive and Brain Sciences  
Minerva Research Group “Neurocognition of Rhythm in Communication”, Leipzig, Germany*

Corresponding author\*:

Michael Schwartz

Max Planck Institute for Human Cognitive and Brain Sciences

Research Group “Neurocognition of Rhythm in Communication”

Stephanstrasse 1a, 04103 Leipzig, Germany

Tel: +49 341 99402473

Fax: +49 341 99402260

Email: [schwartz@pbs.mpg.de](mailto:schwartz@pbs.mpg.de)



**Abstract**

The ability to assess temporal structure is crucial in order to adapt to an ever-changing environment. Increasing evidence suggests that the supplementary motor area (SMA) is involved in both sensory and sensorimotor processing of temporal structure. However, it is not entirely clear whether the structural differentiation of the SMA translates into functional specialization, and how the SMA relates to other systems that engage in temporal processing, namely the cerebellum and cortico-striatal circuits. Anatomically, the SMA comprises at least two subareas, the rostral pre-SMA and the caudal SMA-proper. Each displays a characteristic pattern of connections to motor and non-motor structures. Crucially, these connections establish a potential hub among cerebellar and cortico-striatal systems, possibly forming a dedicated subcortico-cortical temporal processing network. To further explore the functional role of each SMA subarea, we performed a meta-analysis of functional neuroimaging studies by contrasting activations according to whether they linked with either sensory, sensorimotor, sequential, non-sequential, explicit, non-explicit, subsecond, or suprasedond temporal processing. This procedure yielded a set of functional differences, which mirror the rostro-caudal anatomical dimension. Activations associated with sensory, non-sequential, and suprasedond temporal processing tend to locate to the rostral SMA, while the opposite is true for the caudal SMA. These findings confirm a functional dissociation of pre-SMA and SMA-proper in temporal processing.

Keywords: meta-analysis, fMRI, pre-SMA, SMA-proper, temporal processing, timing

## 1. Introduction

The functional concept of classical motor structures, including the cerebellum, the basal ganglia, and the supplementary motor area (SMA), has changed substantially to consider their participation in non-motor, presumably more cognitive, processes (Strick et al., 2009). One such process that has been attributed to the cerebellum, the basal ganglia, and the SMA alike, is temporal processing, i.e. the mechanisms that underlie the encoding, decoding, and evaluation of temporal structure (for a recent review see Coull et al., 2011).

The SMA is a part of Brodmann area 6 in the medial frontal lobe that is associated with the programming, the generation, and the control of action sequences (Goldberg, 1985; Tanji 1996). Early on, it has been demonstrated that these rather complex functions incorporate a number of temporal characteristics, e.g. the slowing of actions, rhythmic movements, as well as speech motor behavior comprising rhythmic, repetitive, stereotypic, and sustained vocalizations, (Brickner, 1939; Penfield, 1950). More recent neuroanatomical accounts further report structural differences and suggest a dissociation of the SMA along the “VAC line” (a vertical line intersecting the anterior commissure) into the more rostral pre-SMA and the more caudal SMA-proper (Matsuzaka et al., 1992; Picard and Strick, 2001; Lehericy et al., 2004). Correspondingly, “SMA” is used as a generic term, while “pre-SMA” and “SMA-proper” are used as subordinate terms. Remarkably sparse connections between these subareas and specific connections to prefrontal areas and to the non-motor part of the cerebellar dentate nucleus in the case of the pre-SMA, as well as connections to primary motor cortex and to the motor part of the dentate in the case of the SMA-proper, further substantiate the proposed structural heterogeneity of this area (Dum and Strick, 2003; Johansen-Berg et al., 2004; Akkal et al., 2007; Strick et al., 2009). This development towards a more detailed structural description of the SMA is paralleled by an increasingly detailed dissociation within the functional domain (Nachev et al., 2008). For example, considering motor behavior, the pre-SMA engages in the initiation and updating of non-automatized, internally generated movements, as opposed to the SMA-proper, which plays a role in externally generated movements (Kennerley et al., 2004; Passingham et al., 2009). Furthermore, in speech production, activations due to lexical selection, linear sequence encoding, and the control of motor output group along a rostro-caudal gradient from pre-SMA to SMA-proper (Alario et al., 2006). Sequentially organized behavior, as in the above examples, depends

in part on coherent temporal order and may therefore exploit to some extent the temporal coding and temporal processing capacity of the pre-SMA and SMA-proper as integral parts of a dedicated temporal processing network (Macar et al., 2002; Mita et al., 2009). Moreover, the ability to code temporal relations may be necessary in order to establish a temporal link between actions and effects, a function which relies on the pre-SMA (Moore et al., 2010).

Research on temporal processing develops along a number of fundamental dichotomies (Coull and Nobre, 2008), perhaps most importantly the distinction of intrinsic and dedicated models of temporal processing (Ivry and Schlerf, 2008). Intrinsic models assume that temporal processing is inherent to neural dynamics, whereas dedicated models refer to some specialized neural architecture, e.g. the cerebellum or cortico-striatal circuits (Buhusi and Meck, 2005). More specifically, the cerebellum is associated with event-based, automatic temporal processing in the milliseconds range, whereas cortico-striatal circuits engage in attention-dependent temporal processing in the hundreds-of-milliseconds-to-minutes range (Spencer et al., 2003; Ivry and Schlerf, 2008; Meck et al., 2008). Crucially, while these dedicated temporal processing systems may work in parallel, they have been modeled relatively independent of each other. Yet, the SMA connects to both systems, and it has been associated with the “tagging” of temporal attributes and the online timing of stimulus durations (Pastor et al., 2006; Coull et al., 2011). These characteristics make the SMA not only a prime neural substrate of a temporal accumulator (Casini and Vidal, 2011), they also introduce an anatomical basis for interactions between different temporal processing systems across a wide range of durations (Allman and Meck, 2011). Principally, the temporal processing function pertains to both, the pre-SMA and the SMA-proper, and is not restricted to motor behavior. Both SMA subareas instead participate in a wide range of temporal processing tasks, including also sensory temporal processing (Macar et al., 2002; Lewis and Miall, 2003). In line with this proposal, a recent meta-analysis of temporal processing studies reports consistent activation likelihood for the bilateral SMA across different temporal ranges and tasks, albeit without explicitly dissociating between its subareas (Wiener et al., 2010). However, pre-SMA and SMA-proper have been implicated in different aspects of temporal processing (Macar et al., 2006), e.g. attentional allocation to time in the sensory domain, and skillful control of time in the sensorimotor domain, engage pre-SMA and SMA-proper, respectively (Coull et al., 2004; Macar et al., 2006). In order to further specify the role of pre-SMA and SMA-proper in temporal processing, we thus used the contrast between sensory and

sensorimotor temporal processing as a starting point to identify functional differences that may mirror the anatomical dissociation of SMA subareas by means of a meta-analysis of functional neuroimaging studies.

On the one hand, meta-analyses have a number of limitations, mainly due to a need in simplification and generalization. On the other hand, they provide the opportunity to identify commonalities across different studies, as well as trends beyond the scope of individual studies. Furthermore, it is important to note that the focus on SMA function constitutes a fundamental constraint in itself, as studies that do not report activation of the SMA were not considered. However, this procedure is justified to the extent that the right inferior frontal gyrus and the bilateral SMA are in fact the only regions of the brain that are consistently activated across different temporal ranges and task requirements (Wiener et al., 2010). In line with the proposal of the SMA as a hub within a dedicated, integrative subcortico-cortical temporal processing network, we expected to find dissociable clusters of fMRI peak activations for sensory and sensorimotor processing of temporal structure along a rostro-caudal axis propagating from the pre-SMA to the SMA-proper. Besides this primary contrast, we used the same set of studies to explore additional domain-general factors that also do not pertain to a specific task or modality by comparing sequential and non-sequential, explicit and non-explicit, as well as subsecond and (mixed-) suprasedond temporal processing in secondary contrasts. These secondary contrasts were included in order to address some of the issues associated with dedicated temporal processing, i.e. the recruitment of different mechanisms based on temporal range or with attention being explicitly directed towards time.

## **2. Materials and Methods**

For the meta-analysis we compiled a pool of 42 fMRI studies that report data from a total of 604 individual subjects, as well as SMA, pre-SMA, or SMA-proper activation that could be associated with either sensory or sensorimotor processing of temporal structure in healthy human participants. In order to identify eligible studies, we used cross-references, as well as different combinations of relevant keywords (e.g. fMRI, SMA, pre-SMA, SMA-proper, timing, tempo, temporal processing, rate, rhythm, sequence, synchronization) in order to search two online

databases (PubMed, [www.ncbi.nlm.nih.gov/pubmed](http://www.ncbi.nlm.nih.gov/pubmed); ISI Web of Knowledge, [www.isiknowledge.com](http://www.isiknowledge.com)) for respective entries. In this specific context, the term “temporal structure” refers broadly to events that generate subdivisions of time, or intervals, e.g. clicks, tones, flashes, syllables, or finger-taps. Two of the selected studies incorporated both sensory and sensorimotor processing and were thus split accordingly and treated as separate studies.

Although they used partly divergent terminology, most studies made some explicit reference to time, temporal processing, or temporal characteristics in the title, experimental design, or discussion. In accordance with our criterion for a primary contrast, 23 studies qualified as “sensory studies”, i.e. the employed task typically involved some form of estimation, discrimination, or passive exposure to temporal structure and did not require any movement besides a single response button press. The remaining 21 studies qualified as “sensorimotor studies”, indicating that temporal structure was defined by some form of movement, typically via finger-tapping or repetitive syllable production. In a second step, the same studies were then classified as “sequential”, if temporal structure was established over three or more successive events, as “explicit”, if some reference to time or tempo was part of the task instruction or was mentioned to the participants, and as “subsecond”, if temporal structure was defined by intervals shorter than 1000 ms. For each of these secondary contrasts, the remaining studies were then classified as “non-sequential”, “non-explicit”, and “suprasecond”, accordingly. Studies incorporating complex music or speech stimuli, e.g. pieces of music or phrases as well as patient studies were principally not considered. From these studies we extracted coordinates in stereotactic space (Talairach and Tournoux or Montreal Neurological Institute, MNI) for 109 peak activations (50 for sensory temporal processing, 59 for sensorimotor temporal processing) labeled as being located in the SMA, pre-SMA, or SMA-proper (Tab 1.).

Study	part	sen	seq	exp	sub	x	y	z	Comparison / condition
Bengtsson et al., 2009; Cortex (MNI)	17	x	x	x	x	-3	12	54	rhythm sequence vs random
						-3	-12	54	rhythm sequence vs random
						6	15	54	isochronous vs metric & non-metric
Bidet-Caulet et al., 2005; Neuroimage (MNI)	10	x	x	-	x	4	7	57	footstep perception vs resting state
Chen et al., 2008; Cereb Cortex (MNI)	12	x	x	-	-	-8	-4	64	listen with anticipation
						0	-6	69	passive listening

						-2	0	62	listen with anticipation
Coull et al., 2000; Neuropsychologia (MNI)	6	x	-	x	-	-6	6	57	all trials
						9	18	54	all trials
					s	0	3	51	long SOA vs short SOA
Coull et al., 2004; Science (MNI)	12	x	-	x	s	6	3	54	attention to time vs attention to color
									time vs color
Coull et al., 2008; J Cogn Neurosci (MNI)	14	x	-	x	-	12	0	69	time vs color
						0	-3	54	sample during time task
						9	0	69	probe during time task
Ferrandez et al., 2003; Neuroimage (TT)	11	x	-	x	x	-3	9	63	duration vs intensity
						6	18	57	duration vs intensity
Grahn and Brett, 2007; J Cogn Neurosci (MNI)	27	x	x	-	-	-9	6	60	rhythms vs rest
						3	6	66	rhythms vs rest
Grahn and McAuley, 2009; Neuroimage (MNI)	35	x	x	x	-	-4	-4	68	stimuli vs rest
						-6	0	60	stimuli vs rest
						6	0	70	stimuli vs rest
Harrington et al., 2004; Cogn Brain Res (TT)	24	x	-	x	s	7	11	55	encoding phase
Harrington et al., 2010; Cereb Cortex (TT)	20	x	-	x	-	-5	2	54	time discrimination vs sensorimotor control
						-8	0	53	time discrimination vs pitch discrimination
						-1	1	54	time discrimination vs sensorimotor control
Lewis and Miall, 2003a; Neuropsychologia (MNI)	8	x	-	x	x	0	15	54	time vs length
						3	27	48	time vs length
					(s)	3	27	42	time vs length
Livesey et al., 2007; Neuropsychologia (TT)	10	x	-	x	-	3	28	53	time perception
						1	28	53	time perception
Pastor et al., 2006; Neuroimage (MNI)	14	x	-	-	x	12	16	58	auditory temporal discrimination vs spatial
						-4	6	64	temporal discrimination vs spatial
Pouthas et al., 2005; Hum Brain Mapp (MNI)	6	x	-	x	-	3	6	60	estimation vs control
Rao et al., 1997 (TT)	13	x	x	-	-	-1	7	50	pitch discrimination
						-3	7	50	pitch discrimination
Rao et al., 2001; Nature Neuroscience (TT)	17	x	-	x	s	-3	6	58	time vs control
						-3	13	50	time vs control
Schubotz et al., 2000; Neuroimage (TT)	20	x	x	x	-	-3	-3	53	rhythm monitoring vs control
Schubotz and von Cramon, 2001; Cereb Cortex (TT)	12	x	x	x	-	1	12	45	sequencing task vs control
						1	1	50	sequencing vs control

						1	12	45	sequencing vs control
						-2	-7	52	sequencing vs control
Schubotz et al., (2003); Neuroimage (TT)	16	x	x	-	-	-5	9	55	what vs when, where
Shih et al., 2009; Neuroreport (MNI)	17	x	-	x	x	-8	2	64	auditory duration discrimination
						4	6	56	auditory duration discrimination
						4	6	54	visual duration discrimination
						-4	4	62	visual duration discrimination
Smith et al., 2003; Neuroimage (TT)	20	x	-	x	s	6	12	45	timing vs order
						-4	8	47	timing vs order
Tregellas et al., 2006; Neuroimage (MNI)	20	x	-	x	x	-9	15	51	temporal processing
Bengtsson et al., 2005; Eur J Neurosci (MNI)	7	-	x	x	-	-8	-4	56	sequence vs rest
						-8	-4	56	isochronous vs rest
Bijsterbosch et al., 2011; J Cogn Neurosci (MNI)	16	-	x	x	x	-4	-4	54	regular vs rest
						-4	-6	56	subliminal vs rest
						12	4	64	supraliminal vs rest
Bohland and Guenther, 2006; Neuroimage (MNI)	13	-	x	-	x	-2	-2	68	simple syllable, simple sequence
						-2	6	50	simple syllable, simple sequence
						4	4	70	simple syllable, simple sequence
						0	0	66	simple syllable, complex sequence
						-6	10	52	simple syllable, complex sequence
						2	0	66	complex syllable, simple sequence
						0	0	70	complex syllable, complex sequence
Brendel et al., 2010; Neuroimage (MNI)	16	-	x	x	x	6	3	60	long isochronous click train vs baseline
Bueti et al., 2008; J Cogn Neurosci (MNI)	14	-	-	x	-	12	0	60	action vs control for action
						-3	15	51	action vs control for action
Cerasa et al., 2005; Neurosci Lett (MNI)	12	-	x	-	x	-2	-8	64	visually cued motor synchronization vs conventional baseline
						-4	-2	60	visually cued motor synchronization vs

									random baseline
*Chen et al., 2008; Cereb Cortex (MNI)	12	-	x	-	-	-4	-8	60	tapping
						-2	-6	62	tapping
Cunnington et al., 2002; Neuroimage (MNI)	12	-	x	x	-	0	-6	50	externally triggered movements
						2	-4	52	self-initiated movements
Jäncke et al., 2000; Cogn Brain Res (MNI)	8	-	x	x	x	-4	-4	52	auditory synchronization and continuation
						0	0	60	visual synchronization and continuation
Jantzen et al., 2005; Neuroimage (TT)	12	-	x	x	x	-3	-3	57	auditory synchronize, pacing vs rest
						-2	-2	60	auditory synchronize, continuation vs rest
						0	-1	56	auditory syncopate, pacing vs rest
						0	-1	56	auditory syncopate, continuation vs rest
						-1	2	57	visual synchronize, pacing vs rest
						-2	-4	58	visual synchronize, continuation vs rest
						0	2	56	visual syncopate, pacing vs rest
						-1	-7	59	visual syncopate, continuation vs rest
Jantzen et al., 2007; Neuropsychologia (TT)	9	-	x	x	x	8	6	55	syncopate vs synchronize
						4	-11	66	continue vs pacing
Karabanov et al., 2009; Neuroimage (MNI)	12	-	x	-	-	-8	0	54	active conditions
						-14	-10	70	active conditions
						6	4	64	active conditions
Kawashima et al., 2000; J Neurophysiol (TT)	8	-	x	x	s	6	2	56	memory timed vs rest
						2	-4	54	visually cued vs rest
						2	2	58	silent articulation
Macar et al., 2004; Cogn Brain Res (MNI)	13	-	-	x	s	0	-6	57	time
						6	-3	60	time vs force
Pope et al., 2005; Neuroimage (MNI)	13	-	x	x	x	-4	-6	72	equal interval and force
						-4	-6	72	alternating interval, equal force
						-8	-2	50	equal interval, alternating force
						-6	0	50	alternating interval, alternating force
*Rao et al., 1997; J Neurosci (TT)	13	-	x	x	x	-1	-4	54	continuation
						-3	-9	56	continuation
Riecker et al., 2003;	8	-	x	-	x	3	3	54	movements of index

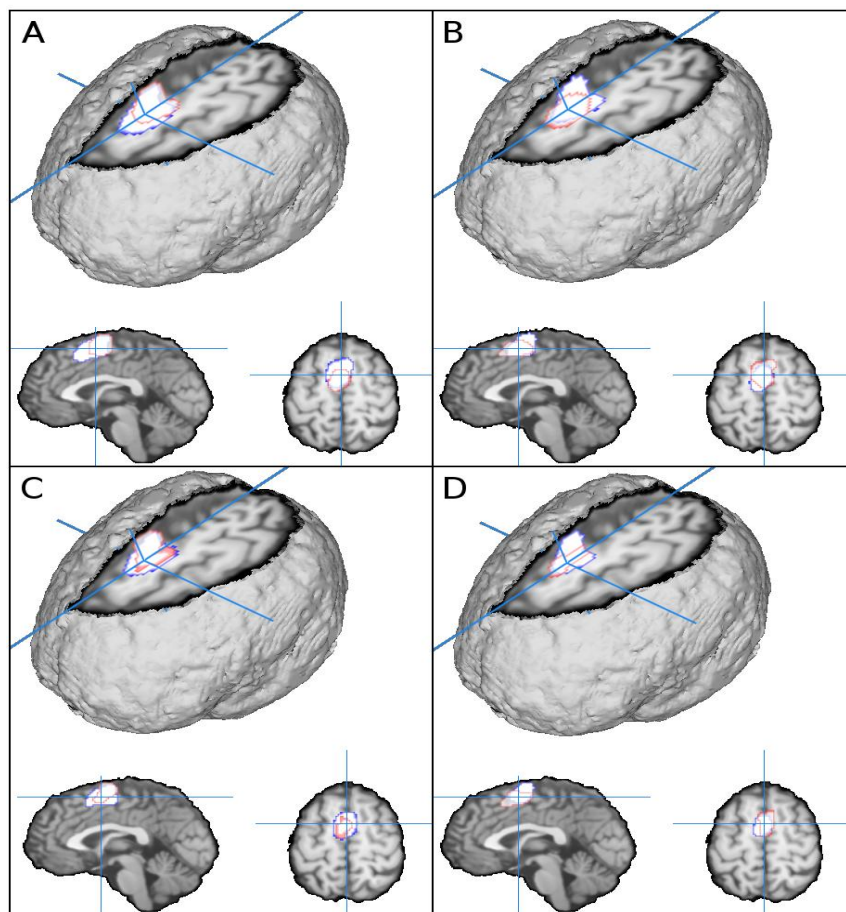


Neuroimage (MNI)									finger
						-6	-15	54	movements of index finger
Riecker et al., 2006; Neuroimage (MNI)	8	-	x	-	x	3	6	63	self-paced syllable repetitions
Taniwaki et al., 2006; Neuroimage (TT)	12	-	x	-	-	4	0	50	self-initiated movement
						2	-2	54	externally-triggered movement
Thaut et al., 2008; PlosOne (MNI)	12	-	x	x	x	-8	-8	68	polyrhythmic and isorhythmic movements vs no movement
						2	-6	70	polyrhythmic and isorhythmic movements vs no movement
						-6	2	68	polyrhythmic and isorhythmic movements vs no movement
						2	2	68	polyrhythmic and isorhythmic movements vs no movement
Toma et al., 2003; Neurosci Lett (TT)	13	-	x	x	s	2	6	49	predictive movement to a regularly presented cue
						10	10	46	reactive movement to a regularly presented cue
					(-)	-4	-1	53	reactive movement to an irregularly presented cue

**Tab. 1.** Studies and coordinates in Talairach space used in the meta-analysis. Part = participants, sen = sensory, seq = sequential, exp = explicit, sub = subsecond (s = suprasedond), \* = sensory and sensorimotor.

The software package GingerAle ([www.brainmap.org/ale/index.html](http://www.brainmap.org/ale/index.html)) was then used to transform coordinates provided in MNI space into Talairach space via the “MNI to Talairach (SPM)” algorithm (Lancaster et al., 2007). In order to determine which algorithm to use, we used a hypothetical coordinate in MNI space ( $x = 0$ ,  $y = 4$ ,  $z = 55$ ), which was obtained by manually locating the level of the VAC line in MNI space by means of an MNI compatible anatomical underlay (colin27\_T1\_seg\_MNI). This coordinate was then transformed into Talairach space via the “MNI (SPM) to Talairach” algorithm (Lancaster et al., 2007; result:  $x = -1$ ,  $y = -3$ ,  $z = 54$ ), and via the “Brett: MNI to Talairach” algorithm (Brett et al., 2002; result:  $x = 1$ ,  $y = 7$ ,  $z = 50$ ). The results for the y-coordinates (i.e., the absolute values for y-coordinates relative to the level of the VAC line at  $y = 0$  in Talairach space) prompted us to use the former algorithm within the specific context of this meta-analysis. However, it is important to note that the transformation

may introduce a bias towards more negative values for y-coordinates relative to the expected location at  $y = 0$ . Solely for the purpose of visualization (Fig. 1), we then used GingerAle to generate cluster overlays from the individual coordinate sets and plotted these overlays onto a Talairach compatible anatomical underlay (colin1.1; Kochunov et al., 2002) by means of the Mango (<http://ric.uthscsa.edu/mango/>) software package, which was also used to generate the surface views depicted in Fig. 1.



**Fig. 1.** Visualizations of coordinate groupings on the basis of cluster overlays generated by GingerAle for (A) sensory (blue) vs. sensorimotor (red), (B) sequential (blue) vs. non-sequential (red), (C) explicit (blue) vs. non-explicit (red), (D) subsecond (blue) vs. suprasecond (red) temporal processing with the crosshair being located at  $x = 0, y = 0, z = 55$ .

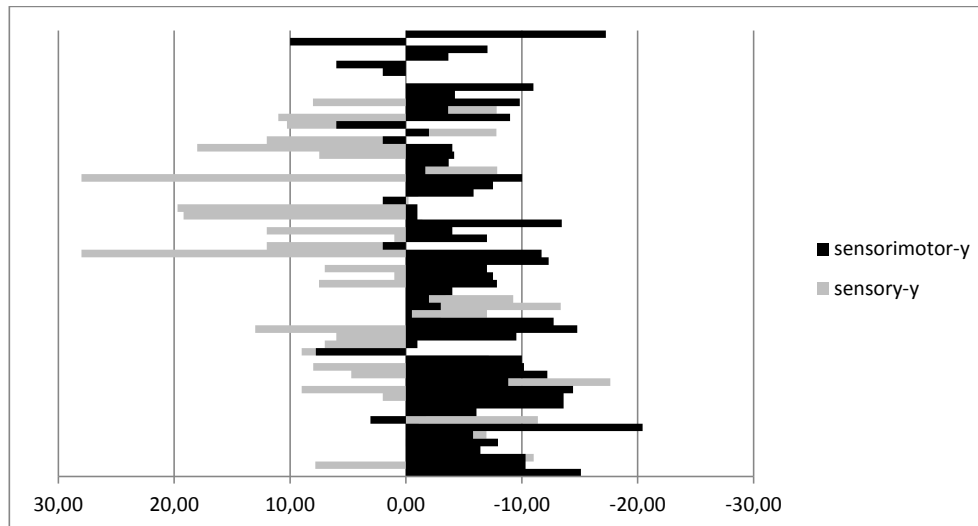
### **3. Results**

Although we were primarily interested in investigating the rostro-caudal dimension of temporal processing within the SMA, we also conducted statistic analyses for the dorso-ventral and lateral dimensions of each dataset and report significant results. However, it is important to note that any difference in the dorso-ventral dimension may reflect both, functional differentiation and/or macroanatomical constraints posed by the medial wall and the outer contour of the brain.

The same statistical procedure was applied for all analyses (using IBM SPSS 19). In a first step, separate Shapiro-Wilks' W tests for normality were conducted for each individual set of x- y- and z-coordinates in Talairach space. If these tests turned out non-significant for the datasets of interest within a specific comparison, e.g. y-coordinates for sensory and sensorimotor temporal processing, an independent samples t-test was conducted to compare the individual datasets. If one or both of the Shapiro-Wilks' W tests turned out significant, we instead used the non-parametric independent samples Mann-Whitney U test to compare the datasets.

#### **3.1 Primary contrast: Sensory versus sensorimotor temporal processing**

Visual inspection of the cluster overlays suggested more caudal clustering for sensorimotor (number of foci / number of experiments in each cluster (F/E) = 59/21) temporal processing relative to a more rostro-caudal clustering for sensory (F/E = 50/23) temporal processing, with an area of overlap located anteriorly and posteriorly of the VAC line. This impression was confirmed by separately plotting the individual y-coordinates from each dataset.



**Fig. 2.** Y-coordinates for the primary contrast between sensory and sensorimotor temporal processing.

There was a significant difference regarding the y-coordinates in the respective datasets ( $t(107) = 5.38, p < .001$ ). However, Levene's test for equality of error variances was significant ( $F(1,107) = 11.69, p < .001$ ). Equal variances not assumed, the result was also significant ( $t(80.13) = 5.19, p < .001$ ). Exclusion of outliers (defined as the five highest and lowest extreme values in each dataset) did not change this outcome either ( $t(66.77) = 6.65, p < .001$ ).

Cluster centers provided by GingerAle were located at  $x = -2, y = 2, z = 55$  for sensory and at  $x = -1, y = -6, z = 57$  for sensorimotor temporal processing with extrema for both located in the left cerebrum, frontal lobe, superior frontal gyrus, BA 6. If the VAC line is taken as a criterion for dissociating pre-SMA and SMA-proper, these results confirm that the primary classification into sensory and sensorimotor temporal processing is adequate in obtaining a difference in rostro-caudal distribution, even if one considers the potential negative shift introduced by the coordinate transformation from MNI into Talairach space. However, further differentiation is necessary in order to account for the results obtained with the secondary contrasts.

### **3.2 Secondary contrast: Sequential versus non-sequential temporal processing**

For the contrast between sequential (F/E = 75/28) and non-sequential (F/E = 34/16) temporal processing, the initial Shapiro-Wilks' W test for normality provided a significant result for the z-coordinates ( $< .05$ ) of the sequential dataset. However, only the contrast for the y-coordinates yielded a significant result ( $t(107) = -5.12, p < .001$ ). Again, Levene's test was significant ( $F(1,107) = 8.32, p < .01$ ), with equal variances not assumed changing the result to ( $t(47.92) = -4.48, p < .001$ ). As for the primary contrast between sensory and sensorimotor studies, this result suggests that a classification according to whether the studies incorporated sequential or non-sequential temporal processing mirrors the rostro-caudal anatomical dimension.

### **3.3 Secondary contrast: Explicit versus non-explicit temporal processing**

Regarding the contrast between explicit (F/E = 79/31) and non-explicit (F/E = 30/13) temporal processing, the initial Shapiro-Wilks' W test was significant for the y- ( $< .01$ ) and the z-coordinates ( $< .03$ ) in the explicit dataset. However, none of the subsequent statistical tests yielded any significant result. The y-coordinates from the two datasets confirmed a trend towards a correlation ( $r = .34, p = .067$ ), indicating that the classification probably did not result in two sufficiently different datasets. This probably explains why the datasets were also inconclusive with respect to a dissociation of pre-SMA and SMA-proper.

### **3.4 Secondary contrast: Subsecond versus (mixed-)suprasecond temporal processing**

The final contrast was between subsecond (F/E = 53/19) and suprasecond temporal processing. However, as several studies incorporated a mixture of subsecond and suprasecond intervals, we decided to compare subsecond temporal processing to both, suprasecond (F/E = 15/9), and mixed-suprasecond (F/E = 56/26) temporal processing, with the former comprising only studies which incorporate intervals with a duration of at least 975 ms. Shapiro-Wilks' W test for normality was significant for the mixed-suprasecond y-coordinates ( $< .02$ ). However, the subsequent analyses yielded significant differences only for the contrast between subsecond and suprasecond temporal processing for x- ( $t(66) = -2.84, p < .01$ ), y-, ( $t(66) = -3.04, p < .01$ ) and z-coordinates ( $t(66) = 3.75, p < .001$ ). Again, these results confirm that the classification was successful in obtaining a difference in rostro-caudal distribution. Averaged x-coordinates from the respective datasets (subsecond: -2; suprasecond: 2) additionally confirm lateralization to the right hemisphere for suprasecond temporal processing.

### **3.5 Post-hoc contrasts**

The primary contrast for sensory and sensorimotor temporal processing yielded a significant result, as did the secondary contrasts for sequential and non-sequential and, subsecond and suprasecond temporal processing. While these findings are in line with the proposed rostro-caudal differentiation of SMA function, the secondary contrasts require further evaluation as the (re-)classification of the original datasets may lead to confounds. More specifically, there was a considerable overlap between some of the datasets, i.e. most sequential studies also classify as sensorimotor (19 out of 28), while most non-sequential studies are at the same time sensory (14 out of 16). This reflects the fact that temporal discrimination is a typical sensory task whereas synchronization to sequential temporal structure is typical for sensorimotor paradigms. The same is true for the subsecond (7 sensory vs. 12 sensorimotor) and suprasecond (6 sensory vs. 3 sensorimotor) datasets. This may lead to classifications that differ in their labels, while the

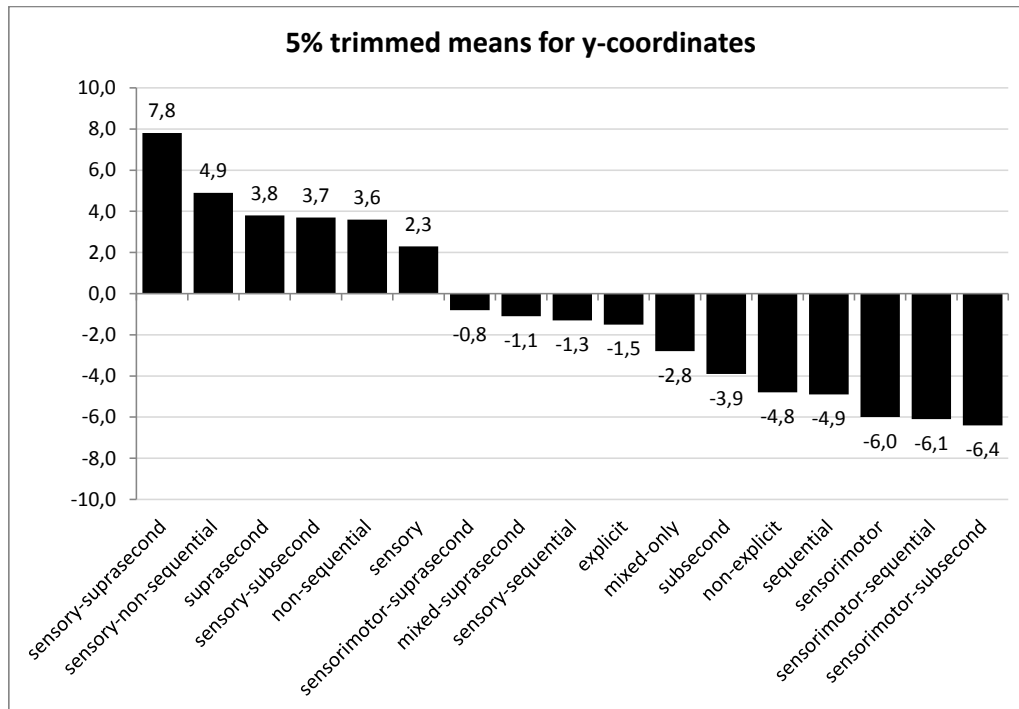
respective datasets lack a corresponding potential for differentiation due to overlaps between the respective entries. Hence, to test for similarities among the datasets, we conducted correlation analyses for y-coordinates from all datasets. There was neither a significant correlation regarding the y-coordinates from the sensorimotor and sequential datasets, nor for sensory and non-sequential datasets. Only subsecond and sequential datasets were correlated ( $r = .403$ ,  $p = .003$ ). However, in order to validate the previous findings, we performed a number of additional analyses in which we contrasted datasets within specific classifications.

First we compared sensory-sequential (F/S = 20/9) to sensorimotor-sequential (F/S = 55/19) studies, thereby eliminating the sequential aspect as a confounding parameter. Shapiro-Wilks' W tests did not provide any significant result, while the subsequent t-tests yielded a significant difference for the y-coordinates ( $t(73) = 2.47$ ,  $p < .02$ ). Levene's test was significant ( $F(1.73) = 4.79$ ,  $p < .04$ ). Equal variances not assumed the result was still significant ( $t(26.36) = 2.11$ ,  $p < .05$ ). Only two studies investigated sensorimotor-non-sequential temporal processing thus rendering a comparison with sensory-non-sequential studies inept.

The same procedure was applied for sensory-subsecond (F/S = 15/7) and sensorimotor-subsecond (F/S = 38/12) studies, thereby eliminating the subsecond aspect. Again, there was a difference regarding the y-coordinates ( $t(51) = 4.72$ ,  $p < .001$ ), with Levene's test significant ( $F(1.51) = 5.06$ ,  $p < .03$ ), and the difference still significant for equal variances not assumed ( $t(18.2) = 3.83$ ,  $p < .01$ ). We then compared sensory-suprasecond (F/S = 8/6) and sensorimotor-suprasecond (F/S = 7/3) studies in order to eliminate the suprasecond aspect. This time the difference in the y-coordinates only approached significance ( $t(13) = 2.01$ ,  $p = .059$ ). However, these results suggest that the difference observed for the primary contrast between sensory and sensorimotor temporal processing indeed reflects a functional difference between pre-SMA and SMA-proper.

Finally, identical analyses were conducted for sensory-sequential (F/S = 20/9) and sensory-non-sequential (F/S = 30/14) studies, thereby eliminating the sensory aspect in that contrast. Again, Shapiro-Wilks' W tests yielded no significant result. There was still a significant difference for y-coordinates ( $t(48) = 2.45$ ,  $p < .02$ ), indicating that the difference between sequential and non-sequential temporal processing is also valid within the sensory domain. Taken together, the results of the primary, the secondary, and the post-hoc contrasts allow for a more concise interpretation of the role of the pre-SMA and SMA-proper in temporal processing

that is in line with the proposed rostro-caudal functional differentiation. In order to illustrate this finding, we plotted 5% trimmed means (i.e. excluding outliers) for y-coordinates of all datasets according to their rostro-caudal distribution (Fig. 3).



**Fig. 3.** Trimmed means for y-coordinates for all datasets used in the statistical analyses. Note that the values for each dataset are plotted according to their relative rostro-caudal distribution after conversion from MNI to Talairach space, i.e. including a potential shift towards more negative values, i.e. towards more caudal locations, introduced by the transformation into Talairach space. Despite this fact, activation associated with suprasecond, sensory, and non-sequential temporal processing, as well as combinations of the latter consistently locate to the pre-SMA.

## 4. Discussion

The current meta-analysis of functional imaging studies identified a set of distributional differences of fMRI activations along a rostro-caudal axis in the SMA that can be associated



with different types of temporal processing. The procedure of pooling data from different sources necessarily introduces a degree of abstraction, which, in the worst case scenario, may contradict some detail observed in an individual data set. Moreover, as the primary criterion for the inclusion in the meta-analysis was the activation of either SMA, pre-SMA, or SMA-proper, we exclusively focused on studies that indeed reported activation of these structures. Nevertheless, it is evident that the performed grouping was adequate in obtaining the expected rostro-caudal clustering of temporal processing mechanisms that is compatible with the dissociation of pre-SMA and SMA-proper. Activation that tended to locate to the pre-SMA was observed in sensory, non-sequential, and suprasedond temporal processing, while activation that tended to locate to the SMA-proper was observed in sensorimotor, sequential, and subsecond temporal processing. Furthermore, suprasedond temporal processing was lateralized to the right hemisphere. This additional finding is compatible with concepts of asymmetric temporal sampling as well as the role of the right dorsolateral prefrontal cortex in suprasedond temporal processing (e.g., Pöppel, 2003; Koch et al., 2007).

The dissociation of SMA function in temporal processing complements the results of the activation likelihood estimation meta-analysis conducted by Wiener et al. (2010), as well as a recent review which links temporal processing in the SMA to externally specified durations (Coull et al., 2011). The latter is the most common setting across temporal processing tasks, which was also the case for the studies included in the current meta-analysis. However, the overlap in an intermediate area indicated by the visualizations of the datasets and the heterogeneous picture resulting from a contrast of “motor timing” and “perceptual timing” (Coull et al., 2011) suggests, that a combination of several factors is required to obtain a more fine grained differentiation of temporal processing functions and detailed anatomical accounts. For example, in the Wiener et al. (2010) meta-analysis a relative criterion was used for the dissociation of subsecond and suprasedond temporal processing, i.e. the respective studies were classified according to whether they incorporated “more” or “less” subsecond or suprasedond intervals. In the current meta-analysis, we only obtained a significant difference for the absolute criterion, i.e. when the datasets employed subsecond or suprasedond intervals only. Nevertheless, the specific pattern of results is in line the proposed role of pre-SMA and SMA-proper as potential hubs among automatic cerebellar and attention-dependent cortico-striato temporal processing systems.

The main purpose of the cerebellar system in this context may be to encode precise event-based representations of temporal structure, possibly via connections to early stages of sensory processing (Petacchi et al., 2005), and to relay this information to the *pre-SMA*, via the thalamus, potentially involving thalamic burst-firing in order to initiate a “wake-up call” for the cortex and subsequent attention-dependent temporal processing in cortico-striatal circuits (Sherman, 2001; Sherman and Guillery, 2002). Via its connections to the *SMA-proper* the cerebellum may likewise engage in the temporally precise shaping of motor output, e.g. during speech production (Ackermann et al., 2007). The encoding and evaluation of temporal inter-event relations, i.e. intervals, initiated by a dopaminergic burst at trial onsets (Buhusi and Meck, 2005), may then take advantage of the circular architecture of cortico-striato-thalamo-cortical connections in order to encode and compare temporal relations retrospectively and repetitively, which in turn may provide a basis for temporal prediction based on temporal regularity (Kotz and Schwartz, 2010).

Not only *pre-SMA* and *SMA-proper* and their connections, but also their target, the basal ganglia, have a rostro-caudal organization (Lehéricy et al., 2004; Postuma and Dagher, 2006; Draganski et al., 2008). This structural congruity probably explains observations of parallel increases in activation within the *pre-SMA* and the caudate nucleus for sensory temporal processing in the suprasecond range (Pouthas et al., 2005). Connections from the *SMA* to the basal ganglia potentially play a role in the heterogeneous temporal processing performance observed in patients with Parkinson’s disease (Merchant et al., 2008). More specifically, a selective loss of pyramidal cells in the *pre-SMA* (McDonald and Halliday, 2002) could contribute to the temporal processing deficits observed in these patients, especially in longer temporal ranges (Smith et al., 2007; Koch et al., 2008). During the early stages of the disease, *pre-SMA* dysfunction may still be compensated for via the recruitment of surrounding areas or via an increase of activity in cerebello-thalamo-cortical connections (Eckert et al., 2006; Cerasa et al., 2006). This in turn may qualify the *SMA* as a possible target for the treatment of Parkinson’s disease (Hamada et al., 2008). However, progress of the disease probably affects the attention-dependent evaluation of temporal relations, thereby possibly also affecting the ability for beat-based rhythm discrimination (Grahn and Brett, 2009).

As temporal processing is indeed crucial to adapt to an ever-changing environment, the underlying connections and the resulting dedicated temporal processing network may represent a

common ground for the perception and production of temporal structure across different modalities in simple and complex dynamic processes such as music or speech processing. This perspective on SMA function may explain earlier reports which, on the one hand, suggested a role of the SMA in the reproduction of sequences requiring a precise timing plan (Halsband et al., 1993), and, on the other hand, report dysfluent speech characterized by preservations, repetitions, and “slowness” as a consequence of SMA lesions (Jonas, 1981; Ziegler et al., 1997).

Taken together, the results of the current meta-analysis confirm a rostro-caudal gradient in the SMA with respect to temporal processing. This supports the functional interpretation of the SMA based on the specific connections of its subareas to other structures implicated in temporal processing. Thus, the function of pre-SMA and SMA-proper can in part be explained by their structural embedding in a dedicated subcortico-cortical temporal processing network.

## 5. References

- Ackermann, H., Mathiak, K., Riecker, A., 2007. The contribution of the cerebellum to speech production and speech perception: clinical and functional imaging data. *Cerebellum*. 6, 202-213.
- Akkal, D., Dum, R.P., Strick, P.L., 2007. Supplementary motor area and presupplementary motor area: targets of basal ganglia and cerebellar output. *J Neurosci*. 27, 10659-10673.
- Alario, F., Chainay, H., Lehericy, S., Cohen, L., 2006. The role of the supplementary motor area (SMA) in word production. *Brain Res*. 1076, 129-143.
- Bengtsson, S.L., Ehrsson, H.H., Forssberg, H., Ullén, F. 2005. Effector-independent voluntary timing: behavioural and neuroimaging evidence. *Eur J Neurosci*. 22, 3255-3265.
- Bengtsson, S.L., Ullén, F., Ehrsson, H.H., Hashimoto, T., Kito, T., Naito, E., Forssberg, H., Sadato, N., 2009. Listening to rhythms activates motor and premotor cortices. *Cortex*. 45, 62-71.
- Bidet-Caulet, A., Voisin, J., Bertrand, O., Fonlupt, P., 2005. Listening to a walking human activates the temporal biological motion area. *Neuroimage*. 28, 132-139.

- Bijsterbosch, J.D., Lee, K., Hunter, M.D., Tsoi, D.T., Lankappa, S., Wilkinson, I.D., Barker, A.T., Woodruff, P.W.R., 2010. The role of the cerebellum in sub- and supraliminal error correction during sensorimotor synchronization: evidence from fMRI and TMS. *J Cogn Neurosci*. 23, 1100-1112.
- Bohland, J., Guenther, F.H., 2006. An fMRI investigation of syllable sequence production. *Neuroimage*. 32, 821-841.
- Brickner, R.M., 1939. A human cortical area producing repetitive phenomena when stimulated. *J Neurophysiol*. 3, 128-130.
- Brett, M.B., Johnsrude, I.S., Owen, A.M., 2002. The problem of functional localization in the human brain. *Nat Rev Neurosci*. 3, 243-249.
- Brendel, B., Hertrich, I., Erb, M., Lindner, A., Riecker, A., Grodd, W., Ackermann, H., 2010. The contribution of mesiofrontal cortex to the preparation and execution of repetitive syllable productions: an fMRI study. *Neuroimage*. 50, 1219-1230.
- Bueti, D., Bahrami, B., Walsh, V., 2008. Sensory and association cortex in time perception. *J Cogn Neurosci*. 20, 1054-1062.
- Buhusi, C.V., Meck, W.H., 2005. What makes us tick? Functional and neural mechanisms of interval timing. *Nat Rev Neurosci*. 6, 755-765.
- Cerasa, A., Hagberg, G.E., Bianciardi, M., Sabatini, U., 2005. Visually cued motor synchronization: modulation of fMRI activation patterns by baseline condition. *Neurosci Lett*. 373, 32-37.
- Cerasa, A., Hagberg, G.E., Peppe, A., Bianciardi, M., Gioia, M.C., Costa, A., Castriota-Scanderberg, A., Caltagirone, C., Sabatini, U., 2006. Functional changes in the activity of cerebellum and frontostriatal regions during externally and internally timed movement in Parkinson's disease. *Brain Res Bull*. 71, 259-269.
- Chen, J.L., Penhune, V.B., Zatorre, R.J., 2008. Listening to musical rhythms recruits motor regions of the brain. *Cereb Cortex*. 18, 2844-2854.
- Coull, J.T., Frith, C.D., Büchel, C., Nobre, A.C., 2000. Orienting attention in time: behavioural and neuroanatomical distinction between exogenous and endogenous shifts. *Neuropsychologia*. 38, 808-819.
- Coull, J.T., Vidal, F., Nazarian, B., Macar, F., 2004. Functional anatomy of the attentional modulation of time estimation. *Science*. 303, 1506-1508.

- Coull, J.T., Nazarian, B., Vidal, F., 2008. Timing, storage, and comparison of stimulus duration engage discrete anatomical components of a perceptual timing network. *J Cogn Neurosci.* 20, 2185-2197.
- Coull, J.T., Cheng, R., Meck, W.H., 2011. Neuroanatomical and neurochemical substrates of timing. *Neuropsychopharmacol.* 36, 3-25.
- Cunnington, R., Windischberger, C., Deecke, L., Moser, E., 2002. The preparation and execution of self-initiated and externally-triggered movement: a study of event-related fMRI. *Neuroimage.* 15, 373-385.
- Draganski, B., Kherif, F., Klöppel, S., Cook, P.A., Alexander, D.C., Parker, G.J.M., Deichmann, R., Ashburner, J., Frackowiak, R.S.J., 2008. Evidence for segregated and integrative connectivity patterns in the basal ganglia. *J Neurosci.* 28, 7143-7152.
- Dum, R.P., Strick, P.L., 2003. An unfolded map of the cerebellar dentate nucleus and its projections to the cerebral cortex. *J Neurophysiol.* 89, 634-639.
- Eckert, T., Peschel, T., Heinze, H., Rotte, M., 2006. Increased pre-SMA activation in early PD patients during simple self-initiated hand movements. *J Neurol.* 253, 199-207.
- Ferrandez, A.M., Hugueville, L., Lehericy, S., Poline, J.B., Marsault, C., Pouthas, V., 2003. Basal ganglia and supplementary motor area subtend duration perception: an fMRI study. *Neuroimage.* 19, 1532-1544.
- Goldberg, G., 1985. Supplementary motor area structure and function: review and hypotheses. *Behav Brain Sci.* 8, 567-616.
- Grahn, J.A., Brett, M., 2007. Rhythm and beat perception in motor areas of the brain. *J Cogn Neurosci.* 19, 893-906.
- Grahn, J.A., Brett, M., 2009. Impairment of beat-based rhythm discrimination in Parkinson's disease. *Cortex.* 45, 54-61.
- Grahn, J.A., McAuley, J.D., 2009. Neural bases of individual differences in beat perception. *Neuroimage.* 47, 1894-1903.
- Halsband, U., Ito, N., Tanji, J., Freund, H., 1993. The role of premotor cortex and the supplementary motor area in the temporal control of movement in man. *Brain* 116, 243-266.
- Hamada, M., Ugawa, Y., Tsuji, S., 2008. High-frequency rTMS over the supplementary motor area for treatment of Parkinson's Disease. *Movement Disord.* 23, 1524-1531.

- Harrington, D.L., Boyd, L.A., Mayer, A.R., Sheltraw, D.M., Lee, R.R., Huang, M., Rao, S.M., 2004. Neural representation of interval encoding and decision making. *Cogn Brain Res.* 21, 193-205.
- Harrington, D.L., Zimbelman, J.L., Hinton, S.C., Rao, S.M., 2010. Neural modulation of temporal encoding, maintenance, and decision processes. *Cereb Cortex.* 20, 1274-1285.
- Ivry, R.B., Schlerf, J.E., 2008. Dedicated and intrinsic models of time perception. *Trends Cogn Sci.* 12, 273-280.
- Jäncke, L., Loose, R., Lutz, K., Specht, K., Shah, N.J., 2000. Cortical activations during paced finger-tapping applying visual and auditory pacing stimuli. *Cognitive Brain Res.* 10, 51-66.
- Jantzen, K.J., Steinberg, F.L., Kelso, J.A.S., 2004. Brain networks underlying human timing behavior are influenced by prior context. *Proc Natl Acad Sci USA.* 101, 6815-6820.
- Jantzen, K.J., Oullier, O., Marshall, M., Steinberg, F.L., Kelso, J.A.S., 2007. A parametric fMRI investigation of context effects in sensorimotor timing and coordination. *Neuropsychologia.* 45, 673-684.
- Johansen-Berg, H., Behrens, T.E.J., Robson, M.D., Drobnyak, I., Rushworth, M.F.S., Brady, J.M., Smith, S.M., Higham, D.J., Matthews, P.M., 2004. Changes in connectivity profiles define functionally distinct regions in human medial frontal cortex. *Proc Natl Acad Sci USA.* 101, 13335-13340.
- Jonas, S., 1981. The supplementary motor region and speech emission. *J Commun Disord.* 14, 349-373.
- Karabanov, A., Blom, Ö., Forsman, L., Ullén, F., 2009. The dorsal auditory pathway is involved in performance of both visual and auditory rhythms. *Neuroimage.* 44, 480-488.
- Kawashima, R., Okuda, J., Umetsu, A., Sigiura, M., Inoue, K., Suzuki, K., Tabuchi, M., Tsukiura, T., Narayan, S.L., Nagasaka, T., Yanagawa, I., Fujii, T., Takahashi, S., Fukuda, H., Yamadori, A., 2000. Human cerebellum plays an important role in memory-timed finger movement: an fMRI study. *J Neurophysiol.* 83, 1079-1087.
- Kennerley, S.W., Sakai, K., Rushworth, M.F.S., 2004. Organization of action sequences and the role of the pre-SMA. *J Neurophysiol.* 91, 978-993.

- Koch, G., Oliveri, M., Torriero, S., Salerno, S., Lo Gerfo, E., Caltagirone, C., 2007. Repetitive TMS of cerebellum interferes with millisecond time processing. *Exp Brain Res.* 179, 291-299.
- Koch, G., Costa, A., Brusa, L., Peppe, A., Gatto, I., Torriero, S., Lo Gerfo, E., Salerno, S., Oliveri, M., Carlesimo, G.A., Caltagirone, C., 2008. Impaired reproduction of second but not millisecond time intervals in Parkinson's Disease. *Neuropsychologia.* 46, 1305-1313.
- Kochunov, P., Lancaster, J., Thompson, P., Toga, A.W., Brewer, P., Hardies, J., Fox, P., 2002. An optimized individual target brain in the Talairach coordinate system. *Neuroimage.* 17, 992-927.
- Kotz, S.A., Schwartze, M., 2010. Cortical speech processing unplugged: a timely subcortico-cortical framework. *Trends Cogns Sci.* 14, 392-399.
- Lancaster, J.L., Tordesillas-Gutiérrez, D., Martínez, M., Salinas, F., Evans, A., Zilles, K., Mazziotta, J.C., Fox, P.T., 2007. Bias between MNI and Talairach coordinates analyzed using the ICBM-152 brain template. *Hum Brain Mapp.* 28, 1194-1205.
- Lehéricy, S., Ducros, M., Krainik, A., Francois, C., Van de Moortele, P., Ugurbil, K., Kim, D., 2004. 3-D diffusion tensor axonal tracking shows distinct SMA and pre-SMA projections to the human striatum. *Cereb Cortex.* 14, 1302-1309.
- Lewis, P.A., Miall, R.C., 2003. Distinct systems for automatic and cognitively controlled time measurement: evidence from neuroimaging. *Curr Opin Neurobiol.* 13, 250-255.
- Lewis, P.A., Miall, R.C., 2003a. Brain activation patterns during measurement of sub- and supra-second intervals. *Neuropsychologia.* 41, 1583-1592.
- Livesey, A.C., Wall, M.B., Smith, A.T., 2007. Time perception: manipulation of task difficulty dissociates clock functions from other cognitive demands. *Neuropsychologia.* 45, 321-331.
- Macar, F., Lejeune, H., Bonnet, M., Ferrara, A., Pouthas, V., Vidal, F., Maquet, P., 2002. Activation of the supplementary motor area and of attentional networks during temporal processing. *Exp Brain Res.* 142, 475-485.
- Macar, F., Anton, J., Bonnet, M., Vidal, F., 2004. Timing functions of the supplementary motor area: an event-related fMRI study. *Cogn Brain Res.* 21, 206-215.
- Macar, F., Coull, J.T., Vidal, F., 2006. The supplementary motor area in motor and perceptual time processing: fMRI studies. *Cogn Process.* 7, 89-94.

- Matsuzaka, Y., Aizawa, H., Tanji, J., 1992. A motor area rostral to the supplementary motor area (presupplementary motor area) in the monkey: neuronal activity during a learned motor task. *J Neurophysiol.* 68, 653-662.
- McDonald, V., Halliday, G.M., 2002. Selective loss of pyramidal neurons in the pre-supplementary motor cortex in Parkinson's disease. *Movements Disord.* 17, 1166-1173.
- Meck, W.H., Penney, T.B., Pouthas, V., 2008. Cortico-striatal representation of time in animals and humans. *Curr Opin Neurobiol.* 18, 145-152.
- Merchant, H., Luciana, M., Hooper, C., Majestic, S., Tuite, P., 2008. Interval timing in Parkinson's disease: heterogeneity in temporal performance. *Exp Brain Res.* 184, 233-248.
- Mita, A., Mushiake, H., Shima, K., Matsuzaka, Y., Tanji, J., 2009. Interval time coding by neurons in the presupplementary and supplementary motor areas. *Nat Neurosci.* 12, 502-507.
- Moore, J.W., Ruge, D., Wenke, D., Rothwell, J., Haggard, P., 2010. Disrupting the experience of control in the human brain: pre-supplementary motor area contributes to the sense of agency. *Proc R Soc B.* 277, 2503-2509.
- Nachev, P., Kennard, C., Husain, M., 2008. Functional role of the supplementary and pre-supplementary motor areas. *Nat Rev Neurosci.* 9, 856-869.
- Passingham, R.E., Bengtsson, S.L., Lau, H.C., 2009. Medial frontal cortex: from self-generated action to reflection on one's own performance. *Trends Cogn Sci.* 14, 16-21.
- Pastor, M.A., Macaluso, E., Day, B.L., Frackowiak, R.S.J., 2006. The neural basis of temporal auditory discrimination. *Neuroimage* 30, 512-520.
- Penfield, W., 1950. The supplementary motor area in the cerebral cortex of man. *Arch Psychiatr Nervenkr Z Gesamte Neurol Psychiatr.* 185, 670-674.
- Petacchi, A., Laird, A.E., Fox, P.T., Bower, J.M., 2005. Cerebellum and auditory function: an ALE meta-analysis of functional neuroimaging studies. *Hum Brain Mapp.* 25, 118-128.
- Picard, N., Strick, P.L., 2001. Imaging the premotor areas. *Curr Opin Neurobiol.* 11, 663-672.
- Poeppel, D., 2003. The analysis of speech in different temporal integration windows: cerebral lateralization as 'asymmetric sampling in time'. *Speech Commun.* 41, 245-255.



- Postuma, R.B., Dagher, A., 2006. Basal ganglia functional connectivity based on a meta-analysis of 126 positron emission tomography and functional magnetic resonance imaging publications. *Cereb Cortex*. 16, 1508-1521.
- Pope, P., Wing, A.M., Praamstra, P., Miall, R.C., 2005. Force related activations in rhythmic sequence production. *Neuroimage*. 27, 909-918.
- Pouthas, V., George, N., Poline, J., Pfeuty, M., Van de Moortele, P., Hugueville, L., Ferrandez, A., Lehericy, S., LeBihan, D., Renault, B., 2005. Neural network involved in time perception: an fMRI study comparing long and short interval estimation. *Hum Brain Mapp*. 25, 433-441.
- Rao, S.M., Harrington, D.L., Haaland, K.Y., Bobholz, J.A., Cox, R.W., Binder, J.R., 1997. Distributed neural systems underlying the timing of movements. *J Neurosci*. 17, 5528-5535.
- Rao, S.M., Mayer, A.R., Harrington, D.L., 2001. The evolution of brain activation during temporal processing. *Nat Neurosci*. 4, 317-323.
- Riecker, A., Wildgruber, D., Mathiak, K., Grodd, W., Ackermann, H., 2003. Parametric analysis of rate-dependent hemodynamic response functions of cortical and subcortical brain structures during auditorily cued finger tapping: a fMRI study. *Neuroimage*. 18, 731-739.
- Riecker, A., Kassubek, J., Gröschel, K., Grodd, W., Ackermann, H., 2006. The cerebral control of speech tempo: opposite relationship between speaking rate and BOLD signal changes at striatal and cerebellar structures. *Neuroimage*. 29, 46-53.
- Schubotz RI, Friederici AD, von Cramon DY. 2000. Time perception and motor timing: a common cortical and subcortical basis revealed by fMRI. *Neuroimage*. 11:1-12.
- Schubotz, R.I., von Cramon, D.Y., 2001. Interval and ordinal properties of sequences are associated with distinct premotor areas. *Cereb Cortex*. 11, 210-222.
- Schubotz, R.I., von Cramon, D.Y., Lohmann, G., 2003. Auditory what, where, and when: a sensory somatotopy in lateral premotor cortex. *Neuroimage*. 20, 173-185.
- Sherman, S.M., 2001. A wake-up call from the thalamus. *Nat Neurosci*. 4, 344-346.
- Sherman, S.M., Guillery, R.W., 2002. The role of the thalamus in the flow of information to the cortex. *Phil Trans R Soc Lond B*. 357, 1695-1708.
- Shih, L.Y.L., Kuo, W., Yeh, T., Tzeng, O.J.L., Hsieh, J., 2009. Common neural mechanisms for explicit timing in the sub-second range. *Neuroreport*. 20, 897-901.

- Smith, A., Taylor, E., Lidzba, K., Rubia, K., 2003. A right hemispheric frontocerebellar network for time discrimination of several hundreds of milliseconds. *Neuroimage*. 20, 344-350.
- Smith, J.G., Harper, D.N., Gittings, D., Abernethy, D., 2007. The effect of Parkinson's disease on time estimation as a function of stimulus duration range and modality. *Brain Cognition*. 64, 130-143.
- Spencer, R.M.C., Zelaznik, H.N., Diedrichsen, J., Ivry, R.B., 2003. Disrupted timing of discontinuous but not continuous movements by cerebellar lesions. *Science*. 300, 1437-1439.
- Strick, P.L., Dum, R.P., Fiez, J.A., 2009. Cerebellum and nonmotor function. *Ann Rev Neurosci*. 32, 413-434.
- Taniwaki, T., Okayama, A., Yoshiura, T., Togao, O., Nakamura, Y., Yamasaki, T., Ogata, K., Shigeto, H., Ohyagi, Y., Kira, J., Tobimatsu, S., 2006. Functional network of the basal ganglia and cerebellar motor loops in vivo: different activation patterns between self-initiated and externally triggered movements. *Neuroimage*. 31, 745-753.
- Tanji, J., 1996. New concepts of the supplementary motor area. *Curr Opin Neurobiol*. 6, 782-787.
- Thaut, M.H., Demartin, M., Sanes, J.N., 2008. Brain networks for integrative rhythm formation. *Plos One*. 3, 1-10.
- Toma, K., Ozawa, M., Matsuo, K., Nakai, T., Fukuyama, H., Sato, S., 2003. The role of the human supplementary motor area in reactive motor operation. *Neurosci Lett*. 344, 177-180.
- Tregellas, J.R., Davalos, D.B., Rojas, D.C., 2006. Effect of task difficulty on the functional anatomy of temporal processing. *Neuroimage*. 32, 307-315.
- Wiener, M., Turkeltaub, P., Coslett, H.B., 2010. The image of time: a voxel-wise meta-analysis. *Neuroimage*. 49, 1728-1740.
- Ziegler, W., Kilian, B., Deger, K., 1997. The role of the left mesial frontal cortex in fluent speech: evidence from a case of left supplementary motor area hemorrhage. *Neuropsychologia*. 35, 1197-1208.



## **IV. Conclusions and future perspectives**



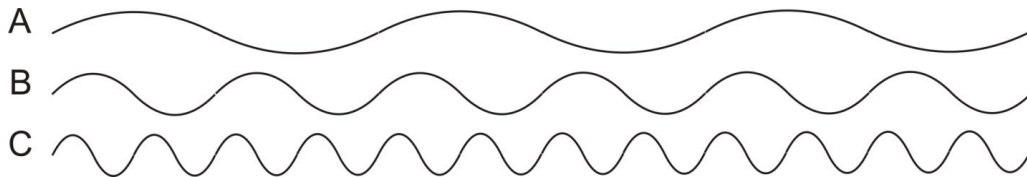
Adaptation to temporal structure via temporal processing is one key to efficient behavior and hence a fundamental aspect of life. The preceding chapters discuss this phenomenon from both theoretical and empirical points of view. Each article of the empirical part refers to specific aspects of the dedicated integrative temporal processing network outlined in the theoretical part. What has become clear in this context is the fact that adaptation to temporal structure and temporal processing are perfect examples for comparably simple concepts that are difficult to explore. This is mostly due to the profound mismatch between a strong intuition on the one hand, and a lack of evidence regarding “time” on the other hand. Inseparably coupled to changes that generate perceivable events, the “sense of time” has so far neither been satisfactorily falsified nor verified. Hence, it is reasonable to consider a compromise and to take a position that originates in the processing of events and inter-event relations, but that stands outside the opposition between processing *in* time and the processing *of* time.

Somewhat independent of this discussion, there are many open questions regarding temporal information and its role in the optimization of behavior. Evidently, temporal structure conveys information about the rate and the rhythm of events. Adaptation of the organism to the rate and the rhythm of events in the environment not only necessitates adequate timing, it also affords adequate timing. As discussed in the previous chapters, in order to refine their timing, individuals need not only consider past events but predict the temporal locus of future events. One way to do this better than at chance level is to exploit temporal patterns, implicitly or explicitly, based on physically real or perceived regularity in temporal structure. Different mechanisms may perform this operation with dedicated temporal processing offering but one explanation among different alternatives. However, while the question regarding the relation of intrinsic and dedicated temporal processing systems cannot yet be resolved conclusively, accumulating evidence suggests that temporal processing engages several brain areas that have traditionally been linked to the control of action.

The role of evolutionary ancient motor areas such as the cerebellum and the basal ganglia in the perception and production of temporal structure may derive from their primordial function in the sequential organization of successive actions. Extending the scope of their function and their interaction with other cortical areas such as the SMA and the DLPFC, these subcortical areas may represent the basis of a dedicated integrative temporal processing network. Starting

with the organization of successive actions, via the quick orienting to potentially threatening events, to the predictive adaptation to temporal structure, such dedicated temporal processing network provides a means to optimize motor skills and cognitive performance alike. In contrast, a dysfunctional temporal processing system may not only impair the ability to perceive and to exploit temporal regularity, it may also lead to profound difficulties regarding timely action as well as in the orienting and tracking of events in the environment. Eventually, this may lead to cognitive decline (McAuley et al., 2006). In this context, the systematic manipulation of temporal structure towards regularity may have different consequences. It may either lead to facilitation on top of unimpaired processing, or lead to compensation in the case of a dysfunctional temporal processing system. This opportunity most likely has implications for various therapeutic applications, including existing approaches, e.g. regarding the treatment of patients with Parkinson's disease (Thaut et al., 2001). However, in order to increase the explanatory power of the introduced framework and to maximize the therapeutic effectiveness, it is certainly necessary to acquire a more detailed picture regarding the contributions of the respective subcortical and cortical areas and their connections. The studies presented in the empirical part of this work represent merely a starting point in this endeavor. Nevertheless, while they address several crucial questions they also provide a basis for further investigations as well as links to current work.

One important open question that needs to be addressed in future studies concerns the issue of "granularity", i.e. the role of events on different timescales. This issue has been hinted at in the definition of event-based temporal processing. However, the dissociation of an event-based representation that is embedded in a more continuous stream of events is but a simplification of the actual problem. Such a dissociation implies differences in temporal resolution and hence also in terms of explicit representations of temporal structure. Furthermore, it suggests that not every event that can principally be distinguished also calls for dedicated temporal processing just as not every event may be relevant in order to optimize behavior. Again, this may be illustrated using the example of speech. In the speech signal prosodic characteristics can be distinguished on at least three levels (Tillmann, 1980; Fig. 11).



**Fig. 11.** ABC prosody. Sound characteristics vary with the rate of modulation. Slow modulation rates convey a continuous impression (A), while the signal loses this continuous quality at intermediate rates and is perceived as a succession of rhythmic pulses (B). Fast modulations again convey a continuous impression. A corresponds to the melodic contour of an utterance, B represents the rhythmic succession of syllables, and C pertains to intrinsic characteristics of speech sounds.

The speech signal conveys information on all three levels simultaneously and in order to recognize the temporal order of events, these events must be distinctive and labeled differently (Pöppel, 1978). Hence, it is probably information on one level (B) that conveys temporal structure which activates dedicated temporal processing mechanisms. While the A-level originates in slow, and the C-level in fast movements, the B-level originates in the mandibular cycle, i.e. opening and closing movements of the mouth (MacNeilage and Davis, 2001; Greenberg et al., 2003; Greenberg, 2006).

It stands to reason whether these characteristics relate, for example, to the differentiation of the thalamic firing modes and/or the asymmetric sampling of auditory information by the two hemispheres. Moreover, whereas the function of an event-based representation of temporal structure has been linked to the orienting and maintenance of attention and attention-dependent temporal processing, the linear representation is assumed to play a role in accessing memory representations. Linear information affords discrimination of formal structure and may be necessary to both store and recall detailed representations of a signal, possibly in some form of an exemplar memory, i.e. representations which retain information about, for example, speaker characteristics (Palmeri et al., 1993; Johnson and Mullennix, 1997; Goldinger, 1998; Port, 2007). Dedicated temporal processing of an event-based representation of temporal structure adds to this process the opportunity to exploit temporal regularity and to attune cognitive processes accordingly.



An obvious way to extend the results regarding sensorimotor synchronization in patients with focal basal ganglia lesions is to investigate patients with cerebellar lesions using the same paradigm (Schwartz et al., 2009). Group-specific findings and a comparison of the two patient groups potentially reveals additional, anatomically specific, properties of the structural network. Furthermore, as attention is the decisive factor in dissociating the contribution of the cerebellum and the basal ganglia to temporal processing, ERPs obtained in attention-dependent settings could prove useful in order to further differentiate between cerebellar and basal ganglia patient groups (Schwartz and Kotz, 2010). However, in addition to the testing of different patient populations, the effects of controlled manipulations of temporal structure, e.g. via grouping of events, requires further investigation, as does its potentially facilitatory and compensatory function (Schwartz et al., 2009a). From a methodological point of view one may also consider a combination of EEG recordings and adaptive sensorimotor synchronization in a single setting (Schwartz et al., 2011b). Another important issue concerns the adaptation of the existing paradigms to additional imaging methods, either with high spatial resolution such as fMRI or good spatial combined with high temporal resolution such as MEG. Together with additional lesion studies such integrative approach deems necessary in order to address both, functional and anatomical aspects, especially within the milliseconds range. In a similar vein, the proposed framework integrates data and hypotheses from a broad range of domains. On the one hand this approach establishes links between different fields of research, while on the other hand it inevitably introduces the risk of neglect to detail. Thus, some components of the network may eventually prove incompatible or may have to be adapted in some specific points, while the general concept of a dedicated integrative temporal processing network itself is still valid.

Temporal processing as a basis for the predictive adaptation to temporal structure provides a means to not only cope with the ever-changing environment but to use the temporal structure of the corresponding events to optimize behavior. In that regard it is crucial to reflect upon the particular benefit of synchronization. Once achieved, the state of being synchronized may establish ideal processing conditions, i.e. a harmonic relation between stimulus-driven bottom-up and top-down processes. In this synchronized state, temporal prediction may complement formal prediction in an optimal way. For example in speech, temporal prediction may converge with predictions on the basis of syntactic, pragmatic, or semantic regularities or “rules” in order to maximally stabilize processing and to facilitate comprehension. Thereby,

temporal structure probably affects all levels of processing, from the orienting of attention towards a speaker or a speech signal, via the extraction of regularity, and up to syntactic levels of processing, with syntax defined as a set of principles which govern the combination of events into sequences (Patel, 2003). Moreover, the facilitatory effect of synchronization may persist, leading to the perceptual imposing of regularity onto temporal structure even if it does not consist of perfect integer ratios, i.e. if perceived regularity does not conform to physical regularity (Gasser et al., 1999). Regarding speech processing, this may lead to retaining a synchronized processing mode even if there is no isochronous temporal structure in the auditory signal, thereby shifting the search for temporal indifference from the signal level to the perceptual level.

The following final remark concerns a speculation rather than an open question. More specifically, the continuous need for adaptation to temporal structure, in combination with continuous attempts to synchronize with temporal structure whenever it is possible may leave an imprint on the individual. In other words, over the life-span, the temporal structure of the environment may exert an influence on the neuropsychological basis of temporal processing and vice versa. This process may affect basic measures such as spontaneous motor tempo or preferred perceptual tempo which in turn reflect different rhythmic properties of the individual (Iwanaga, 1995; Dosseville et al., 2002), as well as age-related processes (Vanneste et al., 2001; Baudouin et al., 2004). Indifference in perceptual temporal processing and preferred production rates may hence reflect a global “average”, shaped by long-term experience with temporal structure. Thus, via structural and functional adaptation to temporal structure the organism is not only able to constantly update his individual point of reference in order to navigate through an ever-changing environment - but is part of this ever-changing environment.



## **V. Bibliography**



- Aitkin, L.M., Boyd, J., 1975. Responses of single units in cerebellar vermis of the cat to monaural and binaural stimuli. *J Neurophysiol* 38, 418-429
- Akkal, D., Dum, R.P., Strick, P.L., 2007. Supplementary motor area and presupplementary motor area: targets of basal ganglia and cerebellar output. *J Neurosci* 27, 10659-10673
- Alexander, G.E., DeLong, M.R., Strick, P.L., 1986. Parallel organization of functionally segregated circuits linking basal ganglia and cortex. *Ann Rev Neurosci* 9, 357-381
- Allan, L.G., 1979. The perception of time. *Percept Psychophys* 26, 340-354
- Allard, F., Scott, B.L., 1975. Burst cues, transition cues, and hemispheric specialization with real speech sounds. *Q J Exp Psychol* 27, 487-497
- Altman, J.A., Bechterev, N.N., Radionova, E.A., Shmigidina, G.N., Syka, J., 1976. Electrical responses of the auditory area of the cerebellar cortex to acoustic stimulation. *Exp Brain Res* 26, 285-298
- Augustinus, 397/398. *Confessions: Book 11*.
- Bar, M., 2007. The proactive brain: using analogies and associations to generate predictions. *Trends Cogn Sci* 11, 280-289
- Barnes, R., Jones, M.R., 2000. Expectancy, attention, and time. *Cogn Psychol* 41, 254-311
- Baruch, C., Panissal-Vieu, N., Drake, C., 2004. Preferred perceptual tempo for sound sequences: comparison of adults, children, and infants. *Percept Mot Skills* 98, 325-339
- Baudouin, A., Vanneste, S., Isingrini, M., 2004. Age-related cognitive slowing: the role of spontaneous tempo and processing speed. *Exp Aging Res* 30, 225-239
- Benedek, G., Perény, J., Kovács, G., Fischer-Szátmári, L., Katoh, Y.Y., 1997. Visual, somatosensory, auditory and nociceptive modality properties in the feline suprageniculate nucleus. *Neurosci* 78, 179-189
- Bignall, K.E., 1970. Auditory input to frontal polysensory cortex of the squirrel monkey: possible pathways. *Brain Res* 19, 77-86
- Bolton, T.L., 1894. Rhythm. *J Psychol* 6, 145-238

- Bostan, A.C., Strick, P.L., 2010. The cerebellum and the basal ganglia are interconnected. *Neuropsychol Rev* 20, 261-270
- Bostan, A.C., Dum, R.P., Strick, P.L., 2010. The basal ganglia communicate with the cerebellum. *Proc Natl Acad Sci USA* 107, 8452-8456
- Bubic, A., von Cramon, D.Y., Schubotz, R.I., 2010. Prediction, cognition and the brain. *Front Hum Neurosci* 4, 1-15
- Budinger, E., Heil, P., Scheich, H., 2000. Functional organization of auditory cortex in the mongolian gerbil (*Meriones unguiculatus*). IV. Connections with anatomically characterized subcortical structures. *Eur J Neurosci* 12, 2452-2474
- Buhusi, C.V., Meck, W.H., 2005. What makes us tick? Functional and neural mechanisms of interval timing. *Nat Rev Neurosci* 6, 755-765
- Buonomano, D.V., 2007. The biology of time across different scales. *Nat Chem Biol* 3, 594-597
- Buzsaki, G., Draguhn, A., 2004. Neuronal oscillations in cortical networks. *Science* 304, 1926-1929
- Coull, J.T., Vidal, F., Nazarian, B., Macar, F., 2004. Functional anatomy of the attentional modulation of time estimation. *Science* 303, 1506-1508
- Coull, J.T., Nobre, A.C., 2008. Dissociating explicit timing from temporal expectation with fMRI. *Curr Opin Neurobiol* 18, 137-144
- Coull, J.T., Nazarian, B., Vidal, F., 2008. Timing, storage, and comparison of stimulus duration engage discrete anatomical components of a perceptual timing network. *J Cogn Neurosci* 20, 2185-2197
- Coull, J.T., Cheng, R., Meck, W.H., 2011. Neuroanatomical and neurochemical substrates of timing. *Neuropsychopharmacol* 36, 3-25
- De la Mothe, L.A., Blumell, S., Kajikawa, Y., Hackett, T.A., 2006. Thalamic connections of the auditory cortex in marmoset monkeys: core and medial belt regions. *J Comp Neurol* 496, 72-96
- Delgutte, B., Kiang, N.Y.S., 1984. Speech coding in the auditory nerve: I. vowel like sounds. *J Acoust Soc Am* 75, 866-878

- Doob, L.W., 1971. *Patterning of time*. Yale University Press, New Haven
- Dosseville, F., Moussay, S., Larude, J., Gauthier, A., Davenne, D., 2002. Physical exercise and time of day: influences on spontaneous motor tempo. *Percept Mot Skills* 95, 965-972
- Dum, R.P., Strick, P.L., 2003. An unfolded map of the cerebellar dentate nucleus and its projections to the cerebral cortex. *J Neurophysiol* 89, 634-639
- Dunn, F.M., 1996. Antiphon on time. *Am J Philology* 117, 65-69
- Draganski, B., Kherif, F., Klöppel, S., Cook, P.A., Alexander, D.C., Parker, G.J.M., Deichmann, R., Ashburner, J., Frackowiak, R.S.J., 2008. Evidence for segregated and integrative connectivity patterns in the basal ganglia. *J Neurosci* 28, 7143-7152
- Drake, C., Botte, M.C., 1993. Tempo sensitivity in auditory sequences: evidence for a multiple-look model. *Percept Psychophys* 54, 277-286
- Drake, C., Jones, M.R., Baruch, C., 2000. The development of rhythmic attending in auditory sequences: attunement, referent period, focal attending. *Cognition* 77, 251-288
- Drake, C., Bertrand, D., 2003. The quest for universals in temporal processing in music. In I. Peretz, R.J. Zatorre (eds). *The cognitive neuroscience of music* (pp. 17-27). Oxford University Press, Oxford
- Engel, A.K., Fries, P., Singer, W., 2001. Dynamic predictions: oscillations and synchrony in top-down processing. *Nat Rev Neurosci* 2, 704-716
- Fraisse, P., 1963. *The psychology of time*. Harper & Row, New York
- Fraisse, P., 1982. Rhythm and tempo. In D. Deutsch (ed). *The psychology of music* (pp. 149 – 180). Academic Press, New York
- Fraisse, P., 1984. Perception and estimation of time. *Ann Rev Psychol* 35, 1-36
- Fraisse, P., 1992. From time lost to time regained. In F. Macar, V. Pouthas, W.J. Friedman (eds). *Time, action and cognition* (pp. 385-392). Kluwer Academic Publishers, Dordrecht



- Fuster, J.M., 1995. Temporal processing. In J. Grafman, K.J. Holyoak, F. Boller (eds). Structure and function of the human prefrontal cortex (pp. 173-181). N. Y. Academy of Sciences, New York
- Fuster, J.M., 2001. The prefrontal cortex – an update: time is of the essence. *Neuron* 30, 319-333
- Gasser, M., Eck, D., Port, R.F., 1999. Meter as mechanism: a neural network model that learns metrical patterns. *Connect Sci* 11, 187-216
- Ghajar, J., Ivry, R.B., 2009. The predictive brain state: asynchrony in disorders of attention. *Neuroscientist* 15, 232-242
- Gibbon, J., Church, R.M., Meck, W.H., 1984. Scalar timing in memory. In J. Gibbon, L. Allan (eds). *Annals of the New York Academy of Sciences*, 423: Timing and time perception (pp. 52-77). N. Y. Academy of Sciences, New York
- Gibbon, J., Church, R.M., 1990. Representation of time. *Cognition* 37, 23-54
- Gibbon, J., Malapani, C., Dale, C.L., Gallistel, C.R., 1997. Towards a neurobiology of temporal cognition: advances and challenges. *Curr Opin Neurobiol*, 7, 170-184
- Gibson, J.J., 1975. Events are perceivable but time is not. In J.T. Fraser, N. Lawrence (eds). *The study of time* (Vol 2; pp. 295-301). Springer, New York
- Glass, L., 2001. Synchronization and rhythmic processes in physiology. *Nature* 410, 277-284
- Goldinger, S.D., 1998. Echoes of echoes? An episodic theory of lexical access. *Psychol Rev* 105, 251-279
- Goody, W., 1958. Time and the nervous system: the brain as a clock. *Lancet*, 1139-1144
- Graybiel, A.M., 1997. The basal ganglia and cognitive pattern generators. *Schizophrenia Bull* 23, 459-469
- Greenberg, S., Carvey, H., Hitchcock, L. & Chang, S. (2003). Temporal properties of spontaneous speech – a syllable-centric perspective. *J Phonetics* 31, 465-485

- Greenberg, S., 2006. A multi-tier framework for understanding spoken language. In S. Greenberg, W.A. Ainsworth (eds). *Listening to speech: an auditory perspective* (pp 411-434). Earlbaum, Mahwah
- Grondin, S., 2001. From physical time to the first and second moments of psychological time. *Psychol Bull* 127, 22-44
- Hackett, T.A., De la Mothe, L.A., Ulbert, I., Karmos, G., Smiley, J. Schroeder, C.E., 2007. Multisensory convergence in auditory cortex, II. Thalamocortical connections of the caudal superior temporal plane. *J Comp Neurol* 502, 924-952
- Hammond, G.R., 1982. Hemispheric differences in temporal resolution. *Brain Cognition* 1, 95-118
- Handel, S., 1974. Perceiving melodic and rhythmic auditory patterns. *J Exp Psychol* 103, 922-933
- He, J., Hu, B., 2002. Differential distribution of burst and single-spike responses in auditory thalamus. *J Neurophys* 88, 2152-2156
- Heath, R.G., Harper, J.W., 1974. Ascending projections of the cerebellar fastigial nucleus to the hippocampus, amygdala, and other temporal lobe sites: evoked potential and histological studies in monkeys and cats. *Exp Neurol* 45, 268-287
- Hickok, G., Poeppel, D., 2000. Towards a functional neuroanatomy of speech perception. *Trends Cogn Sci* 4, 131-138
- Hickok, G., Poeppel, D., 2007. The cortical organization of speech processing. *Nat Rev Neurosci* 8, 393-402
- Hoshi, E., Tremblay, L., Féger, J., Carras, P.L., Strick, P.L., 2005. The cerebellum communicates with the basal ganglia. *Nat Neurosci* 8, 1491-1493
- Huang, C.M., Liu, G., Huang, R., 1982. Projections from the cochlear nucleus to the cerebellum. *Brain Res* 244, 1-8
- Huang, C., Liu, G., 1990. Organization of the auditory area in the posterior cerebellar vermis of the cat. *Exp Brain Res* 81, 377-383

- Huang, C., Liu, G, Yang, B., Mu, H., Hsiao, C., 1991. Auditory receptive area in the cerebellar hemisphere is surrounded by somatosensory areas. *Brain Res* 541, 252-256
- Ivry, R.B., 1996. The representation of temporal information in perception and motor control. *Curr Opin Neurobiol* 6, 851-857
- Ivry, R.B., Spencer, R.M.C., 2004. The neural representation of time. *Curr Opin Neurobiol* 14, 225-232
- Ivry, R.B., Schlerf, J.E., 2008. Dedicated and intrinsic models of time perception. *Trends Cogn Sci* 12, 273-280
- Iwanaga, M., 1995. Harmonic relationship between preferred tempi and heart rate. *Percept Mot Skills* 81, 67-7
- Izhikevich, E.M., 2004. Which model to use for cortical spiking neurons? *IEEE T Neural Networ* 15, 1063- 2004
- Jahanshahi, M., Jones, C.R.G., Dirnberger, G., Frith, C.D., 2006. The substantia nigra pars compacta and temporal processing. *J Neurosci* 26, 12266-12273
- James, W., 1890. *The principles of psychology*. Authorized edition in two volumes (1950 / 1980). Dover, New York
- Jensen, O., Kaiser, J., Lachaux, J., 2007. Human gamma-frequency oscillations associated with attention and memory. *Trends Neurosci* 30, 317-324
- Johansen-Berg, H., Behrens, T.E.J., Robson, M.D., Drobnyak, I., Rushworth, M.F.S., Brady, J.M., Smith, S.M., Higham, D.J., Matthews, P.M., 2004. Changes in connectivity profiles define functionally distinct regions in human medial frontal cortex. *Proc Natl Acad Sci USA* 101, 13335-13340
- Johnson, K., 1997. Speech perception without speaker normalization: an exemplar model. In K. Johnson, J.W. Mullennix (eds). *Talker variability in speech processing* (pp. 145-165). Morgan Kaufmann Publishers, San Francisco
- Jones, M.R., 1976. Time, our lost dimension: toward a new theory of perception, attention, and memory. *Psychol Rev* 83, 323-355

- Jones, M.R., 1985. Structural organization of events in time. In J.A. Michon, J.L. Jackson (eds). Time, mind, and behavior (pp. 192-214). Springer, Berlin
- Jones, M.R., Boltz, M., 1989. Dynamic attending and responses to time. *Psychol Rev* 96, 459-491
- Jones, M.R., Moynihan, H., MacKenzie, N., Puente, J., 2002. Temporal aspects of stimulus-driven attending in dynamic arrays. *Psychol Sci* 13, 313-319
- Jones, C.R.G., Rosenkranz, K., Rothwell, J.C., Jahanshahi, M., 2004. The right dorsolateral prefrontal cortex is essential in time reproduction: an investigation with repetitive transcranial magnetic stimulation. *Exp Brain Res* 158, 366-372
- Jousse, M., 1974. *L'anthropologie du geste*. Gallimard, Paris
- Jueptner, M., Rijntjes, M., Weiller, C., Faiss, J.H., Timmann, D., Mueller, S.P., Diener, H.C., 1995. Localization of a cerebellar timing process using PET. *Neurology* 45, 1540-1545
- Karmarkar, U.R., Buonomano, D.V., 2007. Timing in the absence of clocks: encoding time in neural network states. *Neuron* 53, 427-438
- Kato, H, Tsuzaki, M., Sagisaka, Y., 1998. Acceptability for temporal modification of single vowel segments in isolated words. *J Acoust Soc Am* 104, 540-549
- Kato, H, Tsuzaki, M., Sagisaka, Y., 2003. Functional differences between vowel onsets and offsets in temporal perception of speech: local-change detection and speaking-rate discrimination. *J Acoust Soc Am* 113, 3379-3389
- Katoh, Y.Y., Deura, S., 1993. Direct projections from the cerebellar fastigial nucleus to the thalamic suprageniculate nucleus in the cat studied with the anterograde and retrograde axonal transport of wheat germ agglutinin-horseradish peroxidase. *Brain Res* 617, 155-158
- Katoh, Y.Y., Benedek, G., Deura, S., 1995. Bilateral projections from the superior colliculus to the suprageniculate nucleus in the cat: a WGA-HRP / double fluorescent tracing study. *Brain Res* 669, 298-302
- Kepecs, A., Lisman, J., 2003. Information encoding and computation with spikes and bursts. *Network* 14, 103-118

- Klein, J.C., Behrens, T.E.J., Robson, M.D., Mackay, C.E., Higham, D.J., Johansen-Berg, H., 2007. Connectivity-based parcellation of human cortex using diffusion MRI: establishing reproducibility, validity and observer independence in BA 44/45 and SMA/pre-SMA. *Neuroimage* 34, 204-211
- Kobler, J.B., Isbey, S.F., Casseday, J.H., 1987. Auditory pathways to the frontal cortex of the mustache bat, *pteropus parnellii*. *Science* 236, 824-826
- Koch, G., Oliveri, M., Torriero, S., Salerno, S., Lo Gerfo, E., Caltagirone, C., 2007. Repetitive TMS of cerebellum interferes with millisecond time processing. *Exp Brain Res* 179, 291-299
- Koch, G., Oliveri, M., Caltagirone, C., 2009. Neural networks engaged in milliseconds and seconds time processing: evidence from transcranial magnetic stimulation and patients with cortical or subcortical dysfunction. *Phil Trans R Soc B* 364, 1907-1918
- Kotz SA, Schwartz, M., Schmidt-Kassow, M., 2009. Non-motor basal ganglia functions: a review and proposal for a model of sensory predictability in auditory language perception. *Cortex* 45, 982-990
- Kotz, S.A., Schwartz, M., 2010. Cortical speech processing unplugged: a timely subcortico-cortical framework. *Trends Cogn Sci* 14, 392-399
- Kochanski, G., Orphanidou, C., 2008. What marks the beat of speech? *J Acoust Soc Am* 123, 2780-2791
- Kurokawa, T., Yoshida, K., Yamamoto, T., Oka, H., 1990. Frontal cortical projections from the supragenulate nucleus in the rat, as demonstrated with the PHA-L method. *Neurosci Lett* 120, 259-262
- Kurokawa, T., Saito, H., 1995. Retrograde axonal transport of different fluorescent tracers from the neocortex to the supragenulate nucleus in the rat. *Hear Res* 85, 103-108
- Lakatos, P., Karmos, G., Mehta, A.D., Ulbert, I., Schroeder, C.E., 2008. Entrainment of neuronal oscillations as a mechanism of attentional selection. *Science* 320, 110-113
- Large, E.W., Jones, M.R., 1999. The dynamics of attending: how people track time-varying events. *Psychol Rev* 106, 119-159

- Lashley, K.S., 1951. The problem of serial order in behavior. In L.A. Jeffress (ed). *Cerebral mechanisms in behavior* (pp.112-136). Wiley, New York
- Lee, K., Egleston, P.N., Brown, W.H., Gregory, A.N., Barker, A.T., Woodruff, P.W.R., 2007. The role of the cerebellum in subsecond time perception: evidence from repetitive transcranial magnetic stimulation. *J Cogn Neurosci* 19, 147-157
- Lehéricy, S., Ducros, M., Krainik, A., Francois, C., Van de Moortele, P., Ugurbil, K., Kim, D., 2004. 3-D diffusion tensor axonal tracking shows distinct SMA and Pre-SMA projections to the human striatum. *Cereb Cortex* 14, 1302-1309
- Lewis, P.A., Miall, R.C., 2003. Distinct systems for automatic and cognitively controlled time measurement: evidence from neuroimaging. *Curr Opin Neurobiol* 13, 250-255
- Lewis, P.A., Miall, R.C., 2003a. Brain activation patterns during measurement of sub- and supra-second intervals. *Neuropsychologia* 41, 1583-1592
- Lewis, P.A., Miall, R.C., 2006. Remembering the time: a continuous clock. *Trends Cogn Sci* 10, 401-406
- London, J., 2002. Cognitive constraints on metric systems: some observations and hypotheses. *Music Percept* 19, 529-550
- Lorenzo, D., Velluti, J.C., Crispino, L., Velluti, R., 1977. Cerebellar sensory functions: rat auditory evoked potentials. *Exp Neurol* 55, 629-636
- Macar, F., Coull, J.T., Vidal, F., 2006. The supplementary motor area in motor and perceptual time processing: fMRI studies. *Cogn Process* 7, 89-94
- Mach, E., 1865. Untersuchungen über den Zeitsinn des Ohres - Sitzungsberichte der Akademie der Wissenschaften Wien math.-naturw 51, 133-150
- MacNeilage, P.F., Davis, B.L., 2001. Motor mechanisms in speech ontogeny: phylogenetic, neurobiological and linguistic implications. *Curr Opin Neurobiol* 11, 696-700
- Martin, J.G., 1972. Rhythmic (hierarchical) versus serial structure in speech and other behavior. *Psychol Rev* 79, 487-509

- Matell, M.S., Meck, W.H., 2004. Cortico-striatal circuits and interval timing: coincidence detection of oscillatory processes. *Cognitive Brain Res* 21, 139-170
- Mauk, M.D., Buonomano, D.V., 2004. The neural basis of temporal processing. *Annu Rev Neurosci* 27, 307-340
- McAuley, J.D., Jones, M.R., 2003. Modeling effects of rhythmic context on perceived duration: a comparison of interval and entrainment approaches to short-interval timing. *J Exp Psychol* 29, 1102-1125
- McAuley, J.D., Jones, M.R., Holub, S., Johnston, H.M., Miller, N.S., 2006. The time of our lives: Life span development of timing and event tracking. *J Exp Psychol* 135, 348-367
- McAuley, J.D., Miller, N.S., 2007. Picking up the pace: effects of global temporal context on sensitivity to the tempo of auditory sequences. *Percept Psychophys* 69, 709-718
- McHaffie, J.G., Stanford, T.R., Stein, B.E., Coizet, V., Redgrave, P., 2005. Subcortical loops through the basal ganglia. *Trends Neurosci* 28, 401-407
- Meck, W.H., Malapani, C., 2004. Neuroimaging of interval timing. *Cogn Brain Res* 21, 133-137
- Meck, W.H., 2005. Neuropsychology of timing and time perception. *Brain Cognition* 58, 1-8
- Meck, W.H., Penney, T.B., Pouthas, V., 2008. Cortico-striatal representation of time in animals and humans. *Curr Opin Neurobiol* 18, 145-152
- Miall, C., 1989. The storage of time intervals using oscillating neurons. *Neural Comput* 1, 359-371
- Michon, J.A., 1985. The compleat time experiencer. In J.A. Michon, J.L. Jackson (eds). *Time, mind, and behavior* (pp. 20-52). Springer, Berlin
- Middleton, F.A., Strick, P.L., 2000. Basal ganglia and cerebellar loops: motor and cognitive circuits. *Brain Res Rev* 31, 236-250
- Moore, J.W., Ruge, D., Wenke, D., Rothwell, J., Haggard, P., 2010. Disrupting the experience of control in the human brain: pre-supplementary motor area contributes to the sense of agency. *Proc R Soc B* 277, 2503-2509

- Morest, D.K., Kim, J., Bohne, B.A., 1997. Neuronal and transneuronal degeneration of auditory axons in the brainstem after cochlear lesions in the chinchilla: cochleotopic and non-cochleotopic patterns. *Hear Res* 103, 151-168
- Münsterberg, H., 1889. *Beiträge zur experimentellen Psychologie*, 2. Siebeck, Freiburg
- O'Reilly, J.X., Mesulam, M.M., Nobre, A.C., 2008. The cerebellum predicts the timing of perceptual events. *J Neurosci* 28, 2252-2260
- Palmeri, T.J., Goldinger, S.D., Pisoni, D.B., 1993. Episodic encoding of voice attributes and recognition memory for spoken words. *J Exp Psychol* 19, 309-328
- Parncutt, R., 1994. A perceptual model of pulse salience and metrical accent in musical rhythms. *Music Percept* 11, 409-464
- Paróczy, Z., Nagy, A., Márkus, Z., Waleszczyk, W.J., Wypych, M., Benedek, G., 2006. Spatial and temporal visual properties of single neurons in the suprageniculate nucleus of the thalamus. *Neurosci* 137, 1397-1404
- Parsons, L.M., Petacchi, A., Schmahmann, J.D., Bower, J.M., 2009. Pitch discrimination in cerebellar patients: evidence for a sensory deficit. *Brain Res* 1303, 84-96
- Pastor, M.A., Macaluso, E., Day, B.L., Frackowiak, R.S.J., 2006. The neural basis of temporal auditory discrimination. *Neuroimage* 30, 512-520
- Pastor, M.A., Vidaurre, C., Fernández-Seara, M.A., Villanueva, A., Friston, K.J., 2008. Frequency-specific coupling in the cortico-cerebellar auditory system. *J Neurophysiol* 100, 1699-1705
- Patel, A.D., 2003. Language, music, syntax and the brain. *Nat Rev Neurosci* 6, 674-681
- Petacchi, A., Laird, A.E., Fox, P.T., Bower, J.M., 2005. Cerebellum and auditory function: an ALE meta-analysis of functional neuroimaging studies. *Hum Brain Mapp* 25, 118-128
- Perales, M., Winer, J.A., Prieto, J.J., 2006. Focal projections of cat auditory cortex to the pontine nuclei. *J Comp Neurol* 497, 959-980
- Picard, N., Strick, P.L., 2001. Imaging the premotor areas. *Curr Opin Neurobiol* 11, 663-672



- Pikovsky, A., Rosenblum, M., Kurths, J., 2003. Synchronization: a universal concept in nonlinear sciences. Cambridge Universal Press, Cambridge
- Pöppel, E., 1978. Time perception. In R. Held, W.H. Leibowitz, H. Teuber (eds). Handbook of sensory physiology (pp. 713-729). Springer, Berlin
- Pöppel, E., 1997. A hierarchical model of temporal perception. Trends Cogn Sci 1, 56-61
- Pöppel, E., 2009. Pre-semantically defined temporal windows for cognitive processing. Phil Trans R Soc B 364, 1887-1896
- Port, R.F., 2003. Meter and speech. J Phonetics 31, 599-611
- Port, R.F., 2007. How are words stored in memory? Beyond phones and phonemes. New Ideas Psychol 25, 143-170
- Postuma, R.B., Dagher, A., 2006. Basal ganglia functional connectivity based on a meta-analysis of 126 positron emission tomography and functional magnetic resonance imaging publications. Cereb Cortex 16, 1508-1521
- Rammsayer, T.H., 1999. Neuropharmacological evidence for different timing systems in humans. Q J Exp Psychol B 52, 273-286
- Rao, S.M., Harrington, D.L., Haaland, K.Y., Bobholz, J.A., Cox, R.W., Binder, J.R., 1997. Distributed neural systems underlying the timing of movements. J Neurosci 17, 5528-5535
- Repp, B.H., 2000. Introduction. In L. Windsor, P. Desain (eds). Rhythm perception and Production (pp. 235-237). Swets & Zeitlinger, Lisse
- Repp, B.H., 2005. Sensorimotor synchronization: a review of the tapping literature. Psychon B Rev 12, 969-992
- Rilling, J.K., Glasser, M.F., Preuss, T.M., Ma, X., Zhao, T., Hu, X., Behrens, T.E.J., 2008. The evolution of the arcuate fasciculus revealed with comparative DTI. Nat Neurosci 11, 426-428

- Rouiller, E.M., Liang, F., Babalian, A., Moret, V., Wiesendanger, M., 1994. Cerebellothalamocortical and pallidothalamocortical projections to the primary and supplementary motor cortical areas: a multiple tracing study in macaque monkeys. *J Comp Neurol* 345, 185-213
- Rupert, A.L., Caspary, D.M., Moushegian, G., 1977. Response characteristics of cochlear nucleus neurons to vowel sounds. *Ann Otol Rhinol Laryngol* 86, 37-48
- Sakai, S.T., Inase, M., Tanji, J., 1999. Pallidal and cerebellar inputs to thalamocortical neurons projecting to the supplementary motor area in macaca fuscata: a triple-labeling light microscopic study. *Anat Embryol* 199, 9-19
- Schlerf, J.E., Spencer, R.M.C., Zelaznik, H.N., Ivry, R.B., 2007. Timing of rhythmic movements in patients with cerebellar degeneration. *Cerebellum* 6, 221-231
- Schwartz, M., Keller, P. E., Kotz, S. A., 2009. Spontaneous motor tempo, detection of tempo change and adaptive timing in cerebellar patients. Poster presented at 12th Rhythm perception and production workshop (RPPW), Lille, France
- Schwartz, M., Schmidt-Kassow, M., Kotz, S. A., 2009a. Automatic versus controlled processing of temporal structure. Poster presented at 16th Annual Meeting of the Cognitive Neuroscience Society (CNS), San Francisco, USA
- Schwartz, M., Kotz, S. A., 2010. Dynamic attending and temporal processing in patients with cerebellar or basal ganglia lesions. Poster presented at 17th Annual Meeting of the Cognitive Neuroscience Society (CNS), Montréal, Canada
- Schwartz, M., Keller, P.E., Patel, A.D., Kotz, S.A., 2011. The impact of basal ganglia lesions on sensorimotor synchronization, spontaneous motor tempo, and the detection of tempo changes. *Behav Brain Res* 216, 685-691
- Schwartz, M., Rothermich, K., Schmidt-Kassow, M., Kotz, S.A., 2011a. Temporal regularity effects on pre-attentive and attentive processing of deviance. *Biol Psychol* 87, 146-151
- Schwartz, M., Schmidt-Kassow, M., Kotz, S.A., 2011b. (Sensori-)motor synchronization and its influence on the auditory processing of deviance. Poster presented at 13th Rhythm perception and production workshop (RPPW), Leipzig, Germany

- Schwartz, M., Rothermich, K., Kotz, S.A., 2012. Functional dissociation of pre-SMA and SMA-proper in temporal processing. *Neuroimage* 60, 290-298
- Scott, S.K., McGettigan, C., Eisner, F., 2009. A little more conversation, a little less action – candidate roles for the motor cortex in speech perception. *Nat Rev Neurosci* 10, 295-302
- Shamma, S., 2003. Physiological foundations of temporal integration in the perception of speech. *J Phonetics* 31, 495-501
- Sherman, S.M., 2001. A wake-up call from the thalamus. *Nat Neurosci* 4, 344-346
- Sherman, S.M., Guillery, R.W., 2002. The role of the thalamus in the flow of information to the cortex. *Phil Trans R Soc Lond B* 357, 1695-1708
- Sherman, S.M., Guillery, R.W., 2006. Exploring the role of the thalamus and its role in cortical Function, 2nd edn., MIT Press, Cambridge MA
- Snider, R.S., Stowell, A., 1944. Receiving areas of the tactile, auditory and visual systems in the cerebellum. *J Neurophysiol* 7, 331-357
- Spencer, R.M.C., Zelaznik, H.N., Diedrichsen, J., Ivry, R.B., 2003. Disrupted timing of discontinuous but not continuous movements by cerebellar lesions. *Science* 300, 1437-1439
- Spencer, R.M.C., Karmarkar, U., Ivry, R.B., 2009. Evaluating dedicated and intrinsic models of temporal encoding by varying context. *Phil Trans R Soc B* 364, 1853-1863
- Strick, P.L., Dum, R.P., Fiez, J.A., 2009. Cerebellum and nonmotor function. *Ann Rev Neurosci* 32, 413-434
- Stroud, J.M., 1955. The fine structure of psychological time. In H. Quastler (ed). *Information theory in psychology* (pp. 174-205). Free Press, Glencoe
- Stroud, J.M., 1967. The fine structure of psychological time. *Ann NY Acad Sci* 138, 623-631
- Surwillo, W.W., 1966. Time perception and the ‘internal clock’: some observations on the role of the electroencephalogram. *Brain Res* 2, 390-392
- Taber, K.H., Strick, P.L., Hurley, R.A., 2005. Rabies and the cerebellum: new methods for tracing circuits in the brain. *J Neuropsychiatry Clin Neurosci* 17, 133-138

- Tanaka, K., Otani, K., Tokunaga, A., Sugita, S., 1985. The reciprocal connections of the suprageniculate nucleus and the superior colliculus in the rat. *Neurosci Res* 3, 79-85
- Thaut, M.H., McIntosh, K.W., McIntosh, G.C., Hoemberg, V., 2001. Auditory rhythmicity enhances movement and speech motor control in patients with Parkinson's disease. *Funct Neurol* 16, 163-172
- Tourville, J.A., Guenther, F.H., 2011. The DIVA model: a neural theory of speech acquisition and production. *Lang Cognitive Proc* 26, 925-981
- Treisman, M., 1963. Temporal discrimination and the indifference interval. Implications for a model of the "internal clock". *Psychol Monogr* 77, 1-31
- Treisman, M., Cook, N., Naish, P.L.N., MacCrone, J.K., 1994. The internal clock: electroencephalographic evidence for oscillatory processes underlying time perception. *Q J Exp Psychol A* 47, 241-289
- Vanneste, S., Pouthas, V., Wearden, J.H., 2001. Temporal control of rhythmic performance: a comparison between young and old adults. *Exp Aging Res* 27, 83-102
- Vierordt, K., 1868. *Der Zeitsinn nach Versuchen*. Laupp, Tübingen
- Wang, X.F., Woody, C.D., Chizhevsky, V., Gruen, E., Landeira-Fernandez, J., 1991. The dentate nucleus is a short-latency relay of a primary auditory transmission pathway. *Neuroreport* 2, 361-364
- Wang, X., Lu, T., Liang, L., 2003. Cortical processing of temporal modulations. *Speech Commun* 41, 107-121
- Wang, X., Lu, T., Bendor, D., Bartlett, E., 2008. Neural coding of temporal information in auditory thalamus and cortex. *Neurosci* 154, 294-303
- Wearden, J.H., 2001. Internal clocks and the representation of time. In C. Hoerl, T. McCormack (eds). *Time and memory – issues in philosophy and psychology* (pp. 37-58). Clarendon Press, Oxford
- Will, U., Berg, E., 2007. Brain wave synchronization and entrainment to periodic acoustic stimuli. *Neurosci Lett* 424, 55-60

- Winkler, I., Denham, S.L., Nelken, I., 2009. Modeling the auditory scene: predictive regularity representations and perceptual objects. *Trends Cogn Sci* 13, 532-540
- Woodrow, H., 1951. Time perception. In S.S. Stevens (ed). *Handbook of experimental psychology* (pp. 1224-1236). Wiley, New York
- Woody, C.D., Wang, X.F., Gruen, E., 1998. Acoustic transmission in the dentate nucleus I. Changes in activity and excitability after conditioning. *Brain Res* 789, 74-83
- Xi, M.C., Woody, C.D., Gruen, E., 1994. Identification of short latency auditory responsive neurons in the cat dentate nucleus. *Neuroreport* 5, 1567-1570
- Yeterian, E.H., Pandya, D.N., 1998. Corticostriatal connections of the superior temporal region in rhesus monkeys. *J Comp Neurol* 399, 384-402
- You, H., 1994. Defining rhythm: aspects of an anthropology of rhythm. *Cult Med Psychiat* 18, 361-384
- Zatorre, R., Belin, P., 2001. Spectral and temporal processing in human auditory cortex. *Cereb Cortex* 11, 946-953
- Zeki, S., Hulme, O.J., Roulston, B., Atiyah, M., 2008. The encoding of temporally irregular and regular visual patterns in the human brain. *Plos One* 3, 1-6
- Zelkind, I., Spring, J., 1975. *Time Research, 1172 Studies*. Scarecrow Press, Metuchen
- Zhang, S., Sun, X., Jen, P.H.S., 1990. HRP study of neural projections of acoustic signal to the cerebellum of echolocating bats. *Acta Theriol Sinica* 10, 110-113

## List of Figures

1. Adaptation to formal and temporal structure .....	13
2. Temporal processing on different timescales .....	15
3. Temporal processing in the milliseconds range .....	18
4. Illustration of a spectro-temporal profile (STeP) .....	20
5. Periodic oscillation .....	22
6. Two oscillations tracking temporal structure .....	24
7. Core components of a dedicated integrative temporal processing network .....	29
8. Some properties of burst and tonic firing .....	35
9. A graphic representation of an oscillatory-based timing circuit .....	39
10. Production versus perception of temporal structure .....	41
11. ABC Prosody .....	133

### Article I

1. Structural overlay of basal ganglia lesions <sup>3</sup> .....	55
2. Distribution of spontaneous motor tempo .....	58
3. Coefficients of variation for spontaneous motor tempo .....	59
4. Mean intertap intervals as a function of the final sequence inter-onset interval .....	61
5. Adaptation indices for the sequence positions following the tempo change and during continuation tapping .....	62
6. Phase and period correction estimates for tempo accelerations and decelerations .....	63
7. Proportion of responses to tempo changes .....	64
8. Accuracy in the detection of tempo change .....	66

### Article II

1. Stimulus sequences .....	81
2. Pre-attentive session .....	84
3. Attentive session .....	86

---

<sup>3</sup> Original figure numbering maintained within articles.

Article III

1. Visualizations of coordinate groupings on the basis of cluster overlays. .... 111
2. Y-coordinates for the primary contrast between sensory and sensorimotor temporal processing ..... 113
3. Trimmed means for y-coordinates for all datasets used in the statistical analyses ..... 117

## List of Tables

### Article I

1. Mean Asynchrony, mean intertap interval (ITI), and coefficient of variation (CV) of ITIs during synchronization and continuation ..... 64

### Article III

1. Studies and coordinates in Talairach space used in the meta-analysis ..... 106



## List of Abbreviations

<b>BG</b>	Basal Ganglia
<b>CE</b>	Cerebellum
<b>CV</b>	Coefficient of variation
<b>DAT</b>	Dynamic attending theory
<b>DLPFC</b>	Dorso-lateral prefrontal cortex
<b>EEG</b>	Electroencephalogram
<b>ERP</b>	Event-related-potential
<b>fMRI</b>	Functional magnetic resonance imaging
<b>GABA</b>	Gamma-aminobutric acid
<b>Hz</b>	Hertz
<b>IOI</b>	Inter-onset-interval
<b>ISI</b>	Inter-stimulus-interval
<b>ITI</b>	Inter-tap-interval
<b>M1</b>	Primary motor cortex
<b>MA</b>	Mean asynchrony
<b>MMN</b>	Mismatch negativity
<b>MNI</b>	Montreal Neurological Institute
<b>ms</b>	Milliseconds
<b>mV</b>	Millivolt
<b>PD</b>	Parkinson's disease
<b>PFC</b>	Prefrontal cortex
<b>PMC</b>	Premotor cortex
<b>pre-SMA</b>	Presupplementary motor area
<b>RON</b>	Reorienting negativity
<b>rTMS</b>	Repetitive transcranial magnetic stimulation
<b>s</b>	Second(s)
<b>SBF</b>	Striatal beat frequency
<b>SD</b>	Standard deviation
<b>SMA</b>	Supplementary motor area

<b>SMS</b>	Sensorimotor synchronization
<b>SMT</b>	Spontaneous motor tempo
<b>SOA</b>	Stimulus onset asynchrony
<b>STeP</b>	Spectro-temporal profile
<b>TC</b>	Temporal cortex
<b>THAL</b>	Thalamus
<b>VCA (line)</b>	Vertical (line) at the level of the commissura anterior



## **Selbständigkeitserklärung**

Hiermit erkläre ich, dass die vorliegende Arbeit ohne unzulässige Hilfe und ohne Benutzung anderer als der angegebenen Hilfsmittel angefertigt wurde und dass die aus fremden Quellen direkt oder indirekt übernommenen Gedanken in der Arbeit als solche kenntlich gemacht worden sind.

Michael Schwartze

Leipzig, 14. September 2011



## **Deutschsprachige Zusammenfassung**

Die vorliegende Arbeit beschäftigt sich aus neurokognitiver Perspektive mit der Funktion und der Verarbeitung von zeitlichen Informationen. Ausgehend von einer Einordnung der Thematik auf der Basis klassischer und neuerer Positionen innerhalb der Psychologie wird zunächst die Frage diskutiert, inwieweit der zeitlichen Struktur von Umweltereignissen und von individuellen Handlungen ein Informationsgehalt beigemessen werden kann, der unabhängig von der Identität und der Kombination der jeweiligen Ereignisse ist. Mit anderen Worten: Übermittelt die zeitliche Struktur von Ereignissen selbst nützliche Informationen, z.B. in Form zeitlich regelmäßiger Muster, und wenn ja, welche Funktion könnte eine Auswertung dieser Informationen übernehmen?

Im weiteren Verlauf der Arbeit wird in diesem Zusammenhang eine Unterscheidung der zeitlichen und der formalen Struktur von Ereignissen eingeführt. Diese Unterscheidung dient dazu zu verdeutlichen, dass die Verarbeitung zeitlicher Struktur und zeitlicher Muster eine Grundlage für zeitlich spezifische Vorhersagen ist. Die weitere Argumentation baut darauf auf, dass Vorhersagen dieser Art als eine Voraussetzung für effizientes Verhalten angesehen werden können, sowohl was den Ablauf von kognitiven Prozessen und die Zuweisung von kognitiven Ressourcen betrifft, als auch im Hinblick auf eine möglichst präzise Handlungssteuerung. Den Ausgangspunkt für diese Arbeit bildet somit die Annahme, dass sowohl kognitive als auch handlungssteuernde Prozesse einer kontinuierlichen Anpassung, einer dynamischen Synchronisation, des Individuums an die zeitliche Struktur der Umgebung bedürfen, und dass das menschliche Gehirn über entsprechende Mechanismen zur Verarbeitung von zeitlichen Informationen verfügt.

Der sich an diese einleitenden Betrachtungen anschließende theoretische Teil der Arbeit konzentriert sich in erster Linie auf die Einführung und Abgrenzung von verschiedenen kognitiven Aspekten der Verarbeitung von zeitlichen Informationen. Dazu gehören unter anderem die Oppositionen von sehr kurzen Zeitdauern im Millisekundenbereich gegenüber längeren Zeitintervallen im Sekunden- und Minutenbereich, von ereignisbasierten im Gegensatz zu dauerbasierten Prozessen, sowie von aufmerksamkeitsunabhängiger gegenüber aufmerksamkeitsabhängiger Verarbeitung. Daran anknüpfend wird unter der Einbeziehung von neuroanatomischen Gesichtspunkten ein neurokognitiver Rahmen für die Verarbeitung von

zeitlichen Informationen entwickelt, der den Hintergrund für den empirischen Teil der Arbeit bildet.

Dieser integrative neurokognitive Rahmen fußt auf einer Reihe von existierenden Ansätzen, die zwar einerseits inhaltliche Überschneidungen aufweisen, andererseits aber bislang relativ unabhängig voneinander modelliert wurden. Den Ausgangspunkt der Überlegungen bilden dabei zum einen funktionelle Studien, welche auf der Basis von mittels bildgebender Verfahren gewonnener Daten verhältnismäßig übereinstimmend von einer Aktivierung klassischer motorischer Gehirnstrukturen wie dem Kleinhirn oder den Basalganglien bei der Verarbeitung von zeitlichen Informationen berichten. Zum anderen stützen sich die Ausführungen auf strukturelle Studien, deren Forschungsgegenstand primär die neuronalen Verbindungen zwischen den entsprechenden Strukturen darstellen. Zusammengefasst legen diese Studien eine Beteiligung sowohl des Kleinhirns und der Basalganglien, aber auch supplementär-motorischer kortikaler Areale sowohl in der Produktion als auch in der Perzeption von zeitlichen Informationen nahe. Diese Konzeption einer doppelten Funktion einzelner Strukturen in der Verarbeitung von zeitlichen Informationen liegt daher auch dem angesprochenen integrativen Rahmen zu Grunde.

Der erste von drei Artikeln, die den folgenden empirischen Teil der Arbeit ausmachen, beschäftigt sich dementsprechend mit der Rolle der Basalganglien in der sensomotorischen Synchronisation mit einem Umweltreiz. Patienten mit fokalen Läsionen der Basalganglien und gesunde Kontrollprobanden wurden gebeten eine einfache motorische Handlung (tippende Bewegungen eines Fingers) mit einer Reihe von Tonsequenzen zu synchronisieren, von denen die meisten einen Tempowechsel im Millisekundenbereich an einer bestimmten Position innerhalb der Sequenz enthielten. In diesem Fall sollten die Bewegungen dem neuen Tempo angepasst werden und zudem die Richtung des wahrgenommenen Tempowechsels (Beschleunigung oder Verlangsamung) mitgeteilt werden. Zwischen den Gruppen zeigte sich eine Reihe von Unterschieden, die mit der angenommenen Rolle der Basalganglien in der Verarbeitung von zeitlichen Informationen im Einklang stehen. Neben aufmerksamkeitsabhängigen Fehlerkorrekturprozessen erwies sich bei Patienten mit Basalganglienläsionen außerdem auch die Wahrnehmung der Tempowechsel als auffällig. Dieses Ergebnis unterstützt die Annahme, dass den Basalganglien neben der Steuerung von Handlungen auch eine Funktion in der Perzeption von zeitlichen Informationen zukommt.

Der zweite Artikel thematisiert die Opposition von aufmerksamkeitsunabhängiger und aufmerksamkeitsabhängiger Verarbeitung von zeitlichen Informationen. Mit Hilfe der Methode der Ereignis-korrelierten Potentiale des Elektroenzephalogramms wurde der Einfluss zeitlicher Regelmäßigkeit auf die Verarbeitung von seltenen Tönen höherer Frequenz, die in eine Sequenz von häufigen Tönen tieferer Frequenz eingebettet präsentiert wurden untersucht. Dabei stellte sich heraus, dass zeitliche Regelmäßigkeit einen selektiven Einfluss auf die aufmerksamkeitsabhängige Verarbeitung der höheren Töne hat. Dieses Ergebnis unterstützt die Annahme, dass kognitive Ressourcen wie Aufmerksamkeit dynamisch zugewiesen werden, und dass diese Zuweisung durch die zeitliche Struktur der verwendeten Tonsequenzen beeinflusst werden kann.

Der dritte Artikel bedient sich schließlich metaanalytischer Methoden um die Funktion zweier Subareale des supplementär-motorischen Kortex in der Verarbeitung zeitlicher Informationen voneinander abzugrenzen. Dazu wurden die Ergebnisse einer Reihe von Studien zusammengetragen, welche die Verarbeitung von zeitlichen Informationen mittels funktioneller Magnetresonanztomographie untersuchen und diese Ergebnisse entsprechend zuvor definierten Kriterien klassifiziert. Statistische Analysen dieser Klassifizierungen bestätigen, der angenommenen Doppelfunktion der motorischen Strukturen entsprechend, unterschiedliche Rollen der supplementär-motorischen Subareale in der Produktion und der Perzeption von zeitlichen Informationen.

Insgesamt erweisen sich die Ergebnisse der empirischen Studien als kompatibel mit dem zuvor entwickelten integrativen neurokognitiven Rahmen. Somit kann dieser Rahmen als Arbeitsmodell für weitere Studien in diesem Bereich verwendet werden. Die Komplexität und die Reichweite der Thematik erfordern allerdings unbedingt weitergehende experimentelle Studien. Dazu bedarf es sowohl einer Untersuchung weiterer Patientengruppen, wie z.B. Patienten mit fokalen Läsionen des Kleinhirns, aber auch einer Anpassung der bereits etablierten Paradigmen an weitere bildgebende Verfahren mit hoher räumlicher Auflösung wie der funktionellen Magnetresonanztomographie oder hoher zeitlicher und guter räumlicher Auflösung wie der Magnetenzephalographie.





## MPI Series in Human Cognitive and Brain Sciences:

- 1 Anja Hahne  
*Charakteristika syntaktischer und semantischer Prozesse bei der auditiv Sprachverarbeitung: Evidenz aus ereigniskorrelierten Potentialstudien*
- 2 Ricarda Schubotz  
*Erinnern kurzer Zeitdauern: Behaviorale und neurophysiologische Korrelate einer Arbeitsgedächtnisfunktion*
- 3 Volker Bosch  
*Das Halten von Information im Arbeitsgedächtnis: Dissoziationen langsamer corticaler Potentiale*
- 4 Jorge Jovicich  
*An investigation of the use of Gradient- and Spin-Echo (GRASE) imaging for functional MRI of the human brain*
- 5 Rosemary C. Dymond  
*Spatial Specificity and Temporal Accuracy in Functional Magnetic Resonance Investigations*
- 6 Stefan Zysset  
*Eine experimentalpsychologische Studie zu Gedächtnisabrufprozessen unter Verwendung der funktionellen Magnetresonanztomographie*
- 7 Ulrich Hartmann  
*Ein mechanisches Finite-Elemente-Modell des menschlichen Kopfes*
- 8 Bertram Opitz  
*Funktionelle Neuroanatomie der Verarbeitung einfacher und komplexer akustischer Reize: Integration haemodynamischer und elektro-physiologischer Maße*
- 9 Gisela Müller-Plath  
*Formale Modellierung visueller Suchstrategien mit Anwendungen bei der Lokalisation von Hirnfunktionen und in der Diagnostik von Aufmerksamkeitsstörungen*
- 10 Thomas Jacobsen  
*Characteristics of processing morphological structural and inherent case in language comprehension*
- 11 Stefan Kölsch  
*Brain and Music  
A contribution to the investigation of central auditory processing with a new electrophysiological approach*
- 12 Stefan Frisch  
*Verb-Argument-Struktur, Kasus und thematische Interpretation beim Sprachverstehen*
- 13 Markus Ullsperger  
*The role of retrieval inhibition in directed forgetting – an event-related brain potential analysis*
- 14 Martin Koch  
*Measurement of the Self-Diffusion Tensor of Water in the Human Brain*
- 15 Axel Hutt  
*Methoden zur Untersuchung der Dynamik raumzeitlicher Signale*
- 16 Frithjof Kruggel  
*Detektion und Quantifizierung von Hirnaktivität mit der funktionellen Magnetresonanztomographie*
- 17 Anja Dove  
*Lokalisierung an internen Kontrollprozessen beteiligter Hirngebiete mithilfe des Aufgabenwechselparadigmas und der ereigniskorrelierten funktionellen Magnetresonanztomographie*
- 18 Karsten Steinhauer  
*Hirnphysiologische Korrelate prosodischer Satzverarbeitung bei gesprochener und geschriebener Sprache*
- 19 Silke Urban  
*Verbinformationen im Satzverstehen*
- 20 Katja Werheid  
*Implizites Sequenzlernen bei Morbus Parkinson*
- 21 Doreen Nessler  
*Is it Memory or Illusion? Electrophysiological Characteristics of True and False Recognition*
- 22 Christoph Herrmann  
*Die Bedeutung von 40-Hz-Oszillationen für kognitive Prozesse*
- 23 Christian Fiebach  
*Working Memory and Syntax during Sentence Processing.  
A neurocognitive investigation with event-related brain potentials and functional magnetic resonance imaging*
- 24 Grit Hein  
*Lokalisation von Doppelaufgabendefiziten bei gesunden älteren Personen und neurologischen Patienten*
- 25 Monica de Filippis  
*Die visuelle Verarbeitung unbeachteter Wörter. Ein elektro-physiologischer Ansatz*
- 26 Ulrich Müller  
*Die katecholaminerge Modulation präfrontaler kognitiver Funktionen beim Menschen*
- 27 Kristina Uhl  
*Kontrollfunktion des Arbeitsgedächtnisses über interferierende Information*
- 28 Ina Bornkessel  
*The Argument Dependency Model: A Neurocognitive Approach to Incremental Interpretation*

- 29 Sonja Lattner  
*Neurophysiologische Untersuchungen zur auditorischen Verarbeitung von Stimminformationen*
- 30 Christin Grünewald  
*Die Rolle motorischer Schemata bei der Objektrepräsentation: Untersuchungen mit funktioneller Magnetresonanztomographie*
- 31 Annett Schirmer  
*Emotional Speech Perception: Electrophysiological Insights into the Processing of Emotional Prosody and Word Valence in Men and Women*
- 32 André J. Szameitat  
*Die Funktionalität des lateral-präfrontalen Cortex für die Verarbeitung von Doppelaufgaben*
- 33 Susanne Wagner  
*Verbales Arbeitsgedächtnis und die Verarbeitung ambiger Wörter in Wort- und Satzkontexten*
- 34 Sophie Manthey  
*Hirn und Handlung: Untersuchung der Handlungsrepräsentation im ventralen prämotorischen Cortex mit Hilfe der funktionellen Magnet-Resonanz-Tomographie*
- 35 Stefan Heim  
*Towards a Common Neural Network Model of Language Production and Comprehension: fMRI Evidence for the Processing of Phonological and Syntactic Information in Single Words*
- 36 Claudia Friedrich  
*Prosody and spoken word recognition: Behavioral and ERP correlates*
- 37 Ulrike Lex  
*Sprachlateralisierung bei Rechts- und Linkshändern mit funktioneller Magnetresonanztomographie*
- 38 Thomas Arnold  
*Computergestützte Befundung klinischer Elektroenzephalogramme*
- 39 Carsten H. Wolters  
*Influence of Tissue Conductivity Inhomogeneity and Anisotropy on EEG/MEG based Source Localization in the Human Brain*
- 40 Ansgar Hantsch  
*Fisch oder Karpfen? Lexikale Aktivierung von Benennungsalternativen bei der Objektbenennung*
- 41 Peggy Bungert  
*Zentralnervöse Verarbeitung akustischer Informationen  
Signalidentifikation, Signallateralisation und zeitgebundene Informationsverarbeitung bei Patienten mit erworbenen Hirnschädigungen*
- 42 Daniel Senkowski  
*Neuronal correlates of selective attention: An investigation of electro-physiological brain responses in the EEG and MEG*
- 43 Gert Wollny  
*Analysis of Changes in Temporal Series of Medical Images*
- 44 Angelika Wolf  
*Sprachverstehen mit Cochlea-Implantat: EKP-Studien mit postlingual ertaubten erwachsenen CI-Trägern*
- 45 Kirsten G. Volz  
*Brain correlates of uncertain decisions: Types and degrees of uncertainty*
- 46 Hagen Huttner  
*Magnetresonanztomographische Untersuchungen über die anatomische Variabilität des Frontallappens des menschlichen Großhirns*
- 47 Dirk Köster  
*Morphology and Spoken Word Comprehension: Electrophysiological Investigations of Internal Compound Structure*
- 48 Claudia A. Hruska  
*Einflüsse kontextueller und prosodischer Informationen in der auditorischen Satzverarbeitung: Untersuchungen mit ereigniskorrelierten Hirnpotentialen*
- 49 Hannes Ruge  
*Eine Analyse des raum-zeitlichen Musters neuronaler Aktivierung im Aufgabenwechselfparadigma zur Untersuchung handlungssteuernder Prozesse*
- 50 Ricarda I. Schubotz  
*Human premotor cortex: Beyond motor performance*
- 51 Clemens von Zerssen  
*Bewusstes Erinnern und falsches Wiedererkennen: Eine funktionelle MRT Studie neuroanatomischer Gedächtniskorrelate*
- 52 Christiane Weber  
*Rhythm is gonna get you. Electrophysiological markers of rhythmic processing in infants with and without risk for Specific Language Impairment (SLI)*
- 53 Marc Schönwiesner  
*Functional Mapping of Basic Acoustic Parameters in the Human Central Auditory System*
- 54 Katja Fiehler  
*Temporospatial characteristics of error correction*
- 55 Britta Stolterfoht  
*Processing Word Order Variations and Ellipses: The Interplay of Syntax and Information Structure during Sentence Comprehension*
- 56 Claudia Danielmeier  
*Neuronale Grundlagen der Interferenz zwischen Handlung und visueller Wahrnehmung*

- 57 Margret Hund-Georgiadis  
*Die Organisation von Sprache und ihre Reorganisation bei ausgewählten, neurologischen Erkrankungen gemessen mit funktioneller Magnetresonanztomographie – Einflüsse von Händigkeit, Läsion, Performanz und Perfusion*
- 58 Jutta L. Mueller  
*Mechanisms of auditory sentence comprehension in first and second language: An electrophysiological miniature grammar study*
- 59 Franziska Biedermann  
*Auditorische Diskriminationsleistungen nach unilateralen Läsionen im Di- und Telenzephalon*
- 60 Shirley-Ann Rüschemeyer  
*The Processing of Lexical Semantic and Syntactic Information in Spoken Sentences: Neuroimaging and Behavioral Studies of Native and Non-Native Speakers*
- 61 Kerstin Leuckefeld  
*The Development of Argument Processing Mechanisms in German. An Electrophysiological Investigation with School-Aged Children and Adults*
- 62 Axel Christian Kühn  
*Bestimmung der Lateralisierung von Sprachprozessen unter besondere Berücksichtigung des temporalen Cortex, gemessen mit fMRT*
- 63 Ann Pannekamp  
*Prosodische Informationsverarbeitung bei normalsprachlichem und deviantem Satzmaterial: Untersuchungen mit ereigniskorrelierten Hirmpotentialen*
- 64 Jan Derrfuß  
*Functional specialization in the lateral frontal cortex: The role of the inferior frontal junction in cognitive control*
- 65 Andrea Mona Philipp  
*The cognitive representation of tasks – Exploring the role of response modalities using the task-switching paradigm*
- 66 Ulrike Toepel  
*Contrastive Topic and Focus Information in Discourse – Prosodic Realisation and Electrophysiological Brain Correlates*
- 67 Karsten Müller  
*Die Anwendung von Spektral- und Waveletanalyse zur Untersuchung der Dynamik von BOLD-Zeitreihen verschiedener Hirnareale*
- 68 Sonja A.Kotz  
*The role of the basal ganglia in auditory language processing: Evidence from ERP lesion studies and functional neuroimaging*
- 69 Sonja Rossi  
*The role of proficiency in syntactic second language processing: Evidence from event-related brain potentials in German and Italian*
- 70 Birte U. Forstmann  
*Behavioral and neural correlates of endogenous control processes in task switching*
- 71 Silke Paulmann  
*Electrophysiological Evidence on the Processing of Emotional Prosody: Insights from Healthy and Patient Populations*
- 72 Matthias L. Schroeter  
*Enlightening the Brain – Optical Imaging in Cognitive Neuroscience*
- 73 Julia Reinholz  
*Interhemispheric interaction in object- and word-related visual areas*
- 74 Evelyn C. Ferstl  
*The Functional Neuroanatomy of Text Comprehension*
- 75 Miriam Gade  
*Aufgabeneinhibition als Mechanismus der Konfliktreduktion zwischen Aufgabenrepräsentationen*
- 76 Juliane Hofmann  
*Phonological, Morphological, and Semantic Aspects of Grammatical Gender Processing in German*
- 77 Petra Augurzky  
*Attaching Relative Clauses in German – The Role of Implicit and Explicit Prosody in Sentence Processing*
- 78 Uta Wolfensteller  
*Habituelle und arbiträre sensorimotorische Verknüpfungen im lateralen prämotorischen Kortex des Menschen*
- 79 Päivi Sivonen  
*Event-related brain activation in speech perception: From sensory to cognitive processes*
- 80 Yun Nan  
*Music phrase structure perception: the neural basis, the effects of acculturation and musical training*
- 81 Katrin Schulze  
*Neural Correlates of Working Memory for Verbal and Tonal Stimuli in Nonmusicians and Musicians With and Without Absolute Pitch*
- 82 Korinna Eckstein  
*Interaktion von Syntax und Prosodie beim Sprachverstehen: Untersuchungen anhand ereigniskorrelierter Hirnpotentiale*
- 83 Florian Th. Siebörger  
*Funktionelle Neuroanatomie des Textverstehens: Kohärenzbildung bei Witzen und anderen ungewöhnlichen Texten*

- 84 Diana Böttger  
*Aktivität im Gamma-Frequenzbereich des EEG: Einfluss demographischer Faktoren und kognitiver Korrelate*
- 85 Jörg Bahlmann  
*Neural correlates of the processing of linear and hierarchical artificial grammar rules: Electrophysiological and neuroimaging studies*
- 86 Jan Zwickel  
*Specific Interference Effects Between Temporally Overlapping Action and Perception*
- 87 Markus Ullsperger  
*Functional Neuroanatomy of Performance Monitoring: fMRI, ERP, and Patient Studies*
- 88 Susanne Dietrich  
*Vom Brüllen zum Wort – MRT-Studien zur kognitiven Verarbeitung emotionaler Vokalisationen*
- 89 Maren Schmidt-Kassow  
*What's Beat got to do with ist? The Influence of Meter on Syntactic Processing: ERP Evidence from Healthy and Patient populations*
- 90 Monika Lück  
*Die Verarbeitung morphologisch komplexer Wörter bei Kindern im Schulalter: Neurophysiologische Korrelate der Entwicklung*
- 91 Diana P. Szameitat  
*Perzeption und akustische Eigenschaften von Emotionen in menschlichem Lachen*
- 92 Beate Sabisch  
*Mechanisms of auditory sentence comprehension in children with specific language impairment and children with developmental dyslexia: A neurophysiological investigation*
- 93 Regine Oberecker  
*Grammatikverarbeitung im Kindesalter: EKP-Studien zum auditorischen Satzverstehen*
- 94 Şükrü Barış Demiral  
*Incremental Argument Interpretation in Turkish Sentence Comprehension*
- 95 Henning Holle  
*The Comprehension of Co-Speech Iconic Gestures: Behavioral, Electrophysiological and Neuroimaging Studies*
- 96 Marcel Braß  
*Das inferior frontale Kreuzungsareal und seine Rolle bei der kognitiven Kontrolle unseres Verhaltens*
- 97 Anna S. Hasting  
*Syntax in a blink: Early and automatic processing of syntactic rules as revealed by event-related brain potentials*
- 98 Sebastian Jentschke  
*Neural Correlates of Processing Syntax in Music and Language – Influences of Development, Musical Training and Language Impairment*
- 99 Amelie Mahlstedt  
*The Acquisition of Case marking Information as a Cue to Argument Interpretation in German An Electrophysiological Investigation with Pre-school Children*
- 100 Nikolaus Steinbeis  
*Investigating the meaning of music using EEG and fMRI*
- 101 Tilmann A. Klein  
*Learning from errors: Genetic evidence for a central role of dopamine in human performance monitoring*
- 102 Franziska Maria Korb  
*Die funktionelle Spezialisierung des lateralen präfrontalen Cortex: Untersuchungen mittels funktioneller Magnetresonanztomographie*
- 103 Sonja Fleischhauer  
*Neuronale Verarbeitung emotionaler Prosodie und Syntax: die Rolle des verbalen Arbeitsgedächtnisses*
- 104 Friederike Sophie Haupt  
*The component mapping problem: An investigation of grammatical function reanalysis in differing experimental contexts using event-related brain potentials*
- 105 Jens Brauer  
*Functional development and structural maturation in the brain's neural network underlying language comprehension*
- 106 Philipp Kanske  
*Exploring executive attention in emotion: ERP and fMRI evidence*
- 107 Julia Grieser Painter  
*Music, meaning, and a semantic space for musical sounds*
- 108 Daniela Sammler  
*The Neuroanatomical Overlap of Syntax Processing in Music and Language - Evidence from Lesion and Intracranial ERP Studies*
- 109 Norbert Zmyj  
*Selective Imitation in One-Year-Olds: How a Model's Characteristics Influence Imitation*
- 110 Thomas Fritz  
*Emotion investigated with music of variable valence – neurophysiology and cultural influence*
- 111 Stefanie Regel  
*The comprehension of figurative language: Electrophysiological evidence on the processing of irony*

- 112 Miriam Beisert  
*Transformation Rules in Tool Use*
- 113 Veronika Krieghoff  
*Neural correlates of Intentional Actions*
- 114 Andreja Bubić  
*Violation of expectations in sequence processing*
- 115 Claudia Männel  
*Prosodic processing during language acquisition: Electrophysiological studies on intonational phrase processing*
- 116 Konstanze Albrecht  
*Brain correlates of cognitive processes underlying intertemporal choice for self and other*
- 117 Katrin Sakreida  
*Nicht-motorische Funktionen des prämotorischen Kortex: Patientenstudien und funktionelle Bildgebung*
- 118 Susann Wolff  
*The interplay of free word order and pro-drop in incremental sentence processing: Neurophysiological evidence from Japanese*
- 119 Tim Raettig  
*The Cortical Infrastructure of Language Processing: Evidence from Functional and Anatomical Neuroimaging*
- 120 Maria Golde  
*Premotor cortex contributions to abstract and action-related relational processing*
- 121 Daniel S. Margulies  
*Resting-State Functional Connectivity fMRI: A new approach for assessing functional neuroanatomy in humans with applications to neuroanatomical, developmental and clinical questions*
- 122 Franziska Süß  
*The interplay between attention and syntactic processes in the adult and developing brain: ERP evidences*
- 123 Stefan Bode  
*From stimuli to motor responses: Decoding rules and decision mechanisms in the human brain*
- 124 Christiane Diefenbach  
*Interactions between sentence comprehension and concurrent action: The role of movement effects and timing*
- 125 Moritz M. Daum  
*Mechanismen der frühkindlichen Entwicklung des Handlungsverständnisses*
- 126 Jürgen Dukart  
*Contribution of FDG-PET and MRI to improve Understanding, Detection and Differentiation of Dementia*
- 127 Kamal Kumar Choudhary  
*Incremental Argument Interpretation in a Split Ergative Language: Neurophysiological Evidence from Hindi*
- 128 Peggy Sparenberg  
*Filling the Gap: Temporal and Motor Aspects of the Mental Simulation of Occluded Actions*
- 129 Luming Wang  
*The Influence of Animacy and Context on Word Order Processing: Neurophysiological Evidence from Mandarin Chinese*
- 130 Barbara Ettrich  
*Beeinträchtigung frontomedianer Funktionen bei Schädel-Hirn-Trauma*
- 131 Sandra Dietrich  
*Coordination of Unimanual Continuous Movements with External Events*
- 132 R. Muralikrishnan  
*An Electrophysiological Investigation Of Tamil Dative-Subject Constructions*
- 133 Christian Obermeier  
*Exploring the significance of task, timing and background noise on gesture-speech integration*
- 134 Björn Herrmann  
*Grammar and perception: Dissociation of early auditory processes in the brain*
- 135 Eugenia Solano-Castiella  
*In vivo anatomical segmentation of the human amygdala and parcellation of emotional processing*
- 136 Marco Taubert  
*Plastizität im sensomotorischen System – Lerninduzierte Veränderungen in der Struktur und Funktion des menschlichen Gehirns*
- 137 Patricia Garrido Vásquez  
*Emotion Processing in Parkinson's Disease: The Role of Motor Symptom Asymmetry*