



Negative DC Breakdown Characteristics of C3F7CN and CO2 Mixture with Different Electrode Materials

DOI:

[10.1109/CEIDP50766.2021.9705475](https://doi.org/10.1109/CEIDP50766.2021.9705475)

Document Version

Accepted author manuscript

[Link to publication record in Manchester Research Explorer](#)

Citation for published version (APA):

Bahdad, F. O., Chen, L., & Rowland, S. M. (2022). Negative DC Breakdown Characteristics of C3F7CN and CO2 Mixture with Different Electrode Materials. In *2021 IEEE Conference on Electrical Insulation and Dielectric Phenomena (CEIDP)* (pp. 510-513) Advance online publication. <https://doi.org/10.1109/CEIDP50766.2021.9705475>

Published in:

2021 IEEE Conference on Electrical Insulation and Dielectric Phenomena (CEIDP)

Citing this paper

Please note that where the full-text provided on Manchester Research Explorer is the Author Accepted Manuscript or Proof version this may differ from the final Published version. If citing, it is advised that you check and use the publisher's definitive version.

General rights

Copyright and moral rights for the publications made accessible in the Research Explorer are retained by the authors and/or other copyright owners and it is a condition of accessing publications that users recognise and abide by the legal requirements associated with these rights.

Takedown policy

If you believe that this document breaches copyright please refer to the University of Manchester's Takedown Procedures [<http://man.ac.uk/04Y6Bo>] or contact uml.scholarlycommunications@manchester.ac.uk providing relevant details, so we can investigate your claim.



Negative DC Breakdown Characteristics of C₃F₇CN and CO₂ Mixture with Different Electrode Materials

F. O. Bahdad, L. Chen* and S. M. Rowland
School of Electrical and Electronic Engineering
The University of Manchester
Manchester M13 9PL, UK
*lujia.chen@manchester.ac.uk

Abstract- Sulphur hexafluoride (SF₆) is an insulating medium widely used in the power industry due to its high dielectric strength and arc quenching capability. There is a growing interest in identifying an environmentally friendly alternative to SF₆ and a mixture of C₃F₇CN and CO₂ is one potential candidate. This project investigates the effect of different electrode materials on the breakdown performance of the aforementioned gas mixture over 300 breakdowns under negative DC. Three sets of rod-plane electrodes manufactured in stainless steel, aluminum and brass are tested for a fixed gap distance of 3 mm and pressure of 4.8 bar absolute. The results show that stainless steel has the highest breakdown voltage and the lowest change in surface roughness compared to aluminum and brass. The post-testing gas analyses have shown negligible reduction in the C₃F₇CN content after 300 breakdowns.

I. INTRODUCTION

The most commonly used insulating medium in compressed gas-insulated equipment is SF₆. This is because SF₆ is chemically stable with a high arc quenching capability and high dielectric strength. However, the gas possesses a high global warming potential (GWP) that is 23,500 times greater than CO₂ and a long atmospheric lifetime of 3,200 years. The cumulative environmental impact could pose a significant problem for the power industry [1].

C₃F₇CN is a gas developed by 3MTM and also known as NovecTM 4710 insulating gas. This candidate has many similarities to SF₆ in terms of chemical and physical properties. In addition, this gas has almost double the dielectric strength of SF₆ in its pure form under atmospheric pressure in a uniform field configuration [1]. A key drawback of C₃F₇CN is its high boiling point of -4.7 °C which requires the use of a buffer gas such as CO₂ to minimize the risk of liquefaction in cold climates under higher operating pressures.

Previous investigations show that a 20% C₃F₇CN / 80% CO₂ gas mixture have comparable breakdown performance to SF₆ when tested for uniform and quasi-uniform field configurations in lightning impulse (LI), AC and DC voltage stresses [1-4]. As a result, 20% C₃F₇CN / 80% CO₂ mixture ratio has been chosen for this study. Moreover, the use of a 20% C₃F₇CN and 80% CO₂ mixture can offer 95% reduction in GWP when compared with SF₆ [1]. Thus, this gas could be considered as a potential environmentally friendly gas medium.

A 20% C₃F₇CN / 80% CO₂ gas mixture was tested using a sphere-sphere configuration under 7.2 bar pressure for 1000

negative DC breakdowns [5]. Results show that breakdown voltage reduced from 35 kV down to 20 kV within the first 200 breakdowns and remained consistent for the rest of the experiment. Gas chromatography mass spectrometry (GC-MS) analysis identified CO as one of the major decompositions of 20% C₃F₇CN / 80% CO₂ gas mixture, which is due to the high concentration of CO₂ in the mixture. This is similar to the results shown in [6] for AC where there is little reduction in C₃F₇CN concentration and a small decrease in CO₂ concentration that decomposed to CO. This indicates that the reduced breakdown performance could be attributed to the deformation in electrode surface as opposed to the by-products generated. It was reported in [7] that surface roughness had an effect on the breakdown performance.

Several researchers have reported an influence of electrode materials on the breakdown voltage for SF₆ gas and its mixtures. The commonly used electrode materials are stainless steel, brass, copper, and aluminum [8, 9]. Results show that, stainless steel attain the highest breakdown voltages in comparison with other materials as a result of its high work function and the first ionization energy which is the energy that is required to remove an electron from an electrode atom [8].

This paper examines the combined effects of electrode material and electrical aging on a 20% C₃F₇CN / 80% CO₂ gas mixture. Rod-plane electrodes fabricated in stainless steel aluminum and brass were experimentally examined to determine their breakdown characteristics under DC voltage stress.

II. EXPERIMENTAL SETUP AND TEST TECHNIQUE

A. Electrode Design and Surface Roughness Measurement

A rod-plane configuration with a fixed gap of 3 mm was used to represent a quasi-uniform field commonly found in gas-insulated equipment. COMSOL version 5.3 was used to simulate the maximum electric field (E_{max}) and the field utilization factor, f was calculated by the ratio between the mean electric field (E_{mean}) to the E_{max} .

Figure 1(a) shows the dimensions and Figure 1(b) illustrates the E_{max} simulation of the test configuration with a calculated f of 0.59.

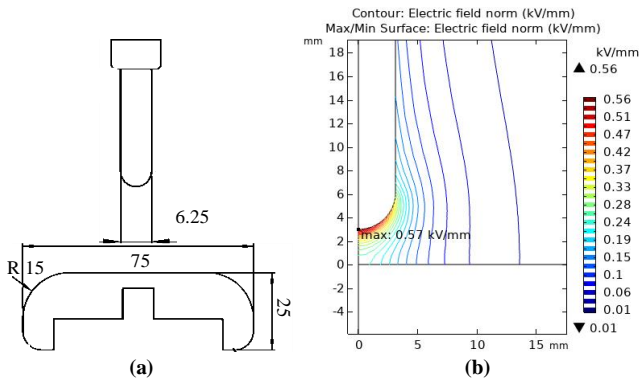

Figure 1. (a) Rod-plane test configuration with dimensions in mm and (b) electric field simulation for a 3 mm gap and 1 kV applied voltage.

The key properties of stainless steel, aluminum and brass are summarized in Table 1. Stainless steel has the highest work function and mechanical robustness in comparison with aluminum and brass. Therefore, it is expected to have the highest breakdown voltage and least surface damage.

Table 1. Material specifications for the stainless steel, aluminum, and brass electrodes [10-13].

Material	Tensile strength (MPa)	Hardness (HB)	Melting Point (°C)	Work Function (eV)
Stainless steel 316L	485 – 561	95 – 217	≈1375	≈4.9
Aluminum HE30	295 – 354	95 – 110	≈555	≈4.3
Brass CZ121	360 – 429	90 – 160	≈900	≈3.4

All fabricated electrodes were polished to a mirror surface finish with an average surface roughness (R_a) of 0.2 μm and a maximum surface roughness (R_z) of less than 2 μm . Jenoptik wave line W5 was used to measure R_a and R_z values before and after the testing. All measurements were obtained from the middle of the rod-plane electrode where most of the discharges occur.

Before measuring the surface roughness, the accuracy of the measuring probe was checked against a calibration set (a pre-determined surface roughness block) to ensure the accuracy of the subsequent measurement. Figure 2 shows a photographic example of surface roughness measurement.



Figure 2. Surface roughness measurement of a polished electrode surface.

B. Pressure Vessel and Gas Handling Procedure

A 5 liter stainless steel pressure vessel that can withstand up to 10 bar pressure was fabricated and incorporated with a bushing rated up to 100 kV_{DC}. A side window is fitted to allow viewing of breakdown events and the inter-electrode gap spacing was set using a slip gauge prior to an experiment.

A plug-in digital gauge was used to check the pressure readings for all gas filling stages. Prior to filling with any test gas, the vessel was vacuumed down to 1 mbar. Then, it was filled with CO₂ above atmospheric pressure and left for several hours to absorb any residual impurities. The vessel was again vacuumed down to 1 mbar.

A 20% C₃F₇CN / 80% CO₂ gas mixture was premixed in a storage cylinder based on partial pressure of the binary gas mixture. Detailed gas mixing and handling procedures can be found in [3]. All pressures in the present work are in absolute. A DILO C4-3-039R-R gas multi-analyzer unit was used to measure the gas mixture composition before and after the experiment for different electrode materials. It is capable of measuring C₃F₇CN, CO₂, CO, O₂ and humidity concentrations. The measurement tolerances for all parameters are provided in Table 2.

C. DC Test Setup and Procedure

Figure 3 shows the test circuit for DC breakdowns. The DC test generator is rated at 600 kV and 200 mA with a ripple factor of less than 3%. Breakdown voltage is measured by a resistive voltage divider that is connected to a data logging system via a fiber optic cable. Successive discharge procedure was followed in accordance to BS EN 60060-1:2010 [14]. A 5 kV/s voltage ramp rate is applied until the breakdown has occurred. The time interval between a breakdown and the next voltage ramp was set at 2 minutes. An average value of breakdowns was used to determine the probability of the 50% breakdown voltage (U_{50}) value.

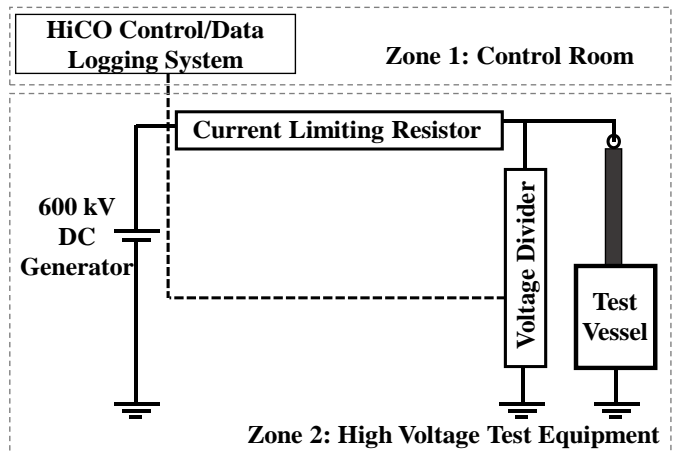

Figure 3. Schematic diagram of the DC breakdown experiment.

III. RESULTS AND DISCUSSION

A. Electrical Breakdown Characteristics

Figure 4 shows the breakdown result of 300 negative DC breakdown for the tested electrode materials under 4.8 bar.

Results in Figure 4 demonstrate that stainless steel has higher breakdown voltage than aluminum and brass electrodes.

Figure 5 presents the average voltage of the first and last 20 breakdowns. As shown in Figure 5, the average voltage of the first 20 breakdowns for both aluminum and stainless steel were comparable with brass being the lowest. This is mainly due to the difference in work function of the electrode materials as it is the minimum energy required to de-attach an electron from a solid surface. Therefore, an electrode material with high work function will attain a higher breakdown voltage [8].

The work function of aluminum is close to the stainless steel one as shown in Table 1. As a result, a comparable breakdown voltage might be expected for the polished electrodes.

In Figure 6, breakdown results were depicted as calculated average of every 20 breakdowns. A gradual declining data trend can be observed for both aluminum and brass test configurations, whereas the breakdown voltage of stainless steel configuration remained relatively consistent until the final 20 breakdowns.

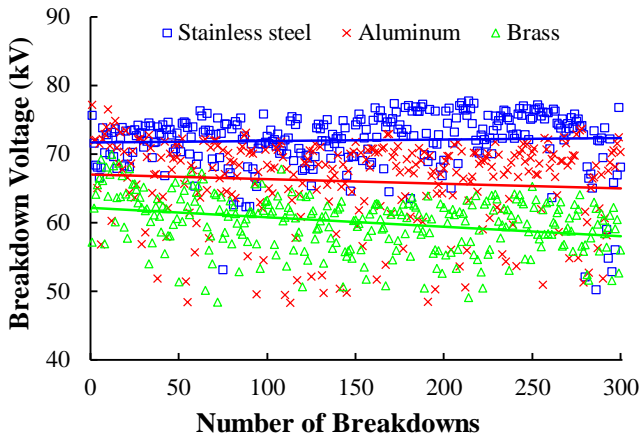

Figure 4. Negative DC breakdown characteristic of 20% C_3F_7CN / 80% CO_2 mixture tested using a rod-plane configuration (rod dia. of 6.25 mm), for stainless steel, aluminum and brass, a fixed gap of 3 mm and a pressure of 4.8 bar. The straight lines represent best fit in each case.

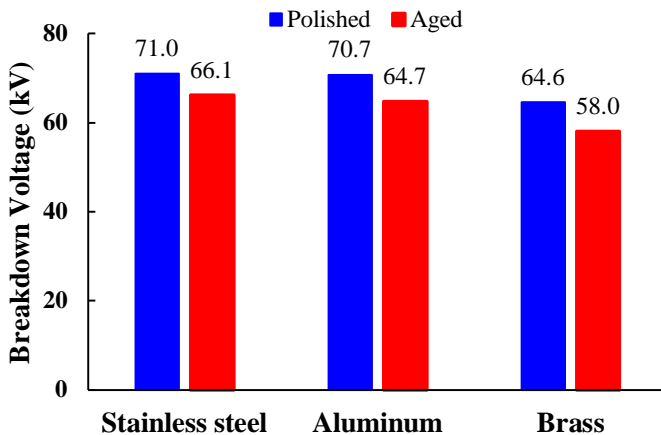

Figure 5. First and last 20 breakdowns averaged from the 300 breakdowns for 20% C_3F_7CN / 80% CO_2 using stainless steel, aluminum, and brass electrodes.

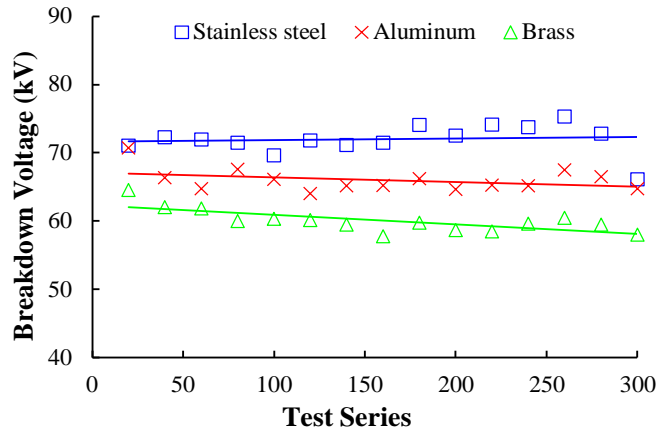

Figure 6. Average values from every 20 breakdowns for aging experiments of 20% C_3F_7CN / 80% CO_2 tested using stainless steel, aluminum and brass electrodes.

Further investigation was carried on the effect of pressure on the aged electrodes from the first set of experiments, Figure 7 shows the results for 4.8, 3 and 2 bar for all three electrode materials.

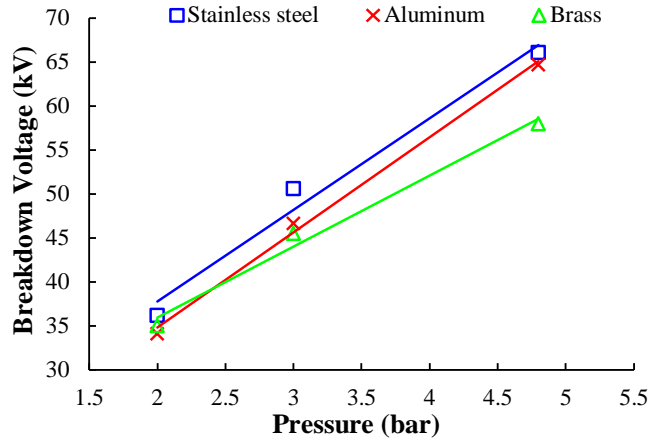

Figure 7. Negative DC breakdown for 20% C_3F_7CN / 80% CO_2 tested using a rod-plane configuration (rod dia. of 6.25 mm), for stainless steel, aluminum and brass, a fixed gap of 3 mm and a pressure of 4.8, 3 and 2 bar.

In [7], it was reported that the effect of electrode surface roughness on the DC breakdown voltage of C_3F_7CN / CO_2 gas mixture is influenced by the gas pressure where the effect of surface roughness is more profound at higher pressures. As shown in Figure 7, all materials show comparable breakdown voltages under 2 bar with greater difference observed for 4.8 bar results. This is in agreement with conclusions in [5]. It also suggested that the effect of electrode surface roughness and material on the breakdown voltage are affected by the gas pressure where the effect will be more significant under higher pressures.

B. Gas Analysis

As shown in Table 2, there is no noticeable change in the C_3F_7CN concentration. However, it is clear that the CO content has increased after 300 breakdowns, which is consistent with previous reported literature [5]. Note that stainless steel configuration had comparatively higher breakdown voltage

which will lead to higher accumulative discharge energy than aluminum and brass electrodes. This could be the reason that experiment with the stainless steel configuration had a comparatively higher CO concentration as shown in Table 2.

Table 2. Gas analysis using DILO C4-3-039R-R gas multi-analyzer unit for C₃F₇CN/CO₂ gas mixture before and after 300 breakdowns under 4.8 bar pressure for stainless steel, aluminum, and brass rod-plane electrode.

Material	Gas	C ₃ F ₇ CN (%)	CO ₂ (%)	CO (ppmv)	O ₂ (%)
	Tolerance	± 0.2%	± 2%	± 2%	± 0.3%
Stainless steel	Before	19.4	83.9	12.0	0.3
	After	19.0	84.0	257.9	0.3
Aluminum	Before	18.4	84.0	12.0	0.4
	After	18.6	83.7	232.9	0.2
Brass	Before	19.1	84.2	15.9	0.3
	After	19.1	83.6	213.6	0.2

C. Electrode Surface Roughness

The declining trend observed in the breakdown voltage shown in Figure 6 is mainly caused by the accumulated surface damage on the tested electrodes. It was reported in [7] that rougher electrode surface has a negative effect on the DC breakdown characteristics of C₃F₇CN / CO₂ gas mixture. Table 3 depicts the measured R_a and R_z pre- and post-aging experiment for all three electrode materials.

Table 3. Surface roughness measurement using Jenoptik wave line W5 device before and after 300 breakdowns for stainless steel, aluminum, and brass at the center of the plane electrode.

Material	Polished Electrode		Aged Electrode	
	R _a (um)	R _z (um)	R _a (um)	R _z (um)
Stainless steel	0.16	1.20	1.32	6.32
Aluminum	0.19	1.81	2.36	11.57
Brass	0.21	1.53	2.11	9.97

Based on the results shown in Table 3, electrode surface roughness for stainless steel increased at least 8 times while aluminum and brass were increased 12 and 10 times respectively after 300 breakdowns. Stainless steel electrodes have less sustained surface damage than aluminum and brass electrodes. Despite the comparatively higher breakdown performance found in stainless steel configuration than aluminum and brass, there is less surface damage on stainless steel due to its mechanical and thermal robustness, and as a result it maintains a comparatively high breakdown performance compared to aluminum and brass, whose performance deteriorates as their surfaces degrade faster.

IV. CONCLUSIONS

The results of this paper show that stainless steel electrodes attained higher breakdown voltage and less surface damage when compared with aluminum and brass. This could be attributed to the comparatively higher work function and

thermal and mechanical robustness of stainless steel. Electrode surface roughness of aluminum and brass was increased by approximately 10 times after 300 negative DC breakdowns. Thus, a decreasing trend of the breakdown voltage was obtained. The measured C₃F₇CN concentration did not vary significantly after an extensive number of DC breakdowns, but the CO concentration was increased to 200 ppmv. This suggests that the reduction in breakdown performance is less likely to be influenced by gas by-products and mainly due to the sensitive of the gas mixture to rougher electrode surfaces.

ACKNOWLEDGMENT

This work was supported by the Dean's Doctoral Scholarship funded by The University of Manchester. The authors also acknowledge EPSRC for support through 'High Voltage Test Systems for Electricity Network Research' [grant number EP/P030343/1]. The authors would also like to thank Dr Richard Gardner for his assistance with the experimental setup.

REFERENCES

- [1] L. Loizou *et al*, "Technical Viability of Retro-Filling C₃F₇CN/CO₂ Gas Mixtures in SF₆ -Designed Gas Insulated Lines and Busbars at Transmission Voltages," *IEEE Trans. Power Deliv.*, vol. 35, no. 5, pp. 2394–2402, 2020.
- [2] L. Loizou, L. Chen, and Q. Liu, "A Comparative Study on the Breakdown Characteristics of SF₆ and 20% C₃F₇CN / 80% CO₂ Gas Mixture in a Coaxial Configuration," *IEEE Conference on Electrical Insulation and Dielectric Phenomena (CEIDP)*, 2019, pp. 234–237.
- [3] L. Loizou *et al*, "Lightning impulse breakdown characteristics of SF₆ and 20% C₃F₇CN / 80% CO₂ mixture under weakly non-uniform electric fields," *IEEE Trans. Dielectr. Electr. Insul.*, vol. 27, no. 3, pp. 848–856, 2020.
- [4] I. Idriessu *et al*, "Negative DC Breakdown Characteristics of C₃F₇CN/CO₂ Gas Mixture for Application in High Voltage Accelerators," *IEEE Trans. Dielectr. Electr. Insul.*, to be published, 2021.
- [5] I. Idriessu *et al*, "Gas Decomposition and Electrode Degradation Characteristics of a 20% C₃F₇CN and 80% CO₂ Gas Mixture for High Voltage Accelerator," *High Volt.*, to be published, pp. 1–10, 2021.
- [6] B. Zhang *et al*, "Decomposition characteristics of C₄F₇N/CO₂ mixture under AC discharge breakdown," *AIP Adv.*, vol. 9, no. 11, p. 115212, 2019.
- [7] X. Ai *et al*, "The effect of electrode surface roughness on the breakdown characteristics of C₃F₇CN/CO₂ gas mixtures," *Int. J. Electr. Power Energy Syst.*, vol. 118, p. 105751, 2020.
- [8] H. Sharifpanah, A. Gholami, and S. Jamali, "Effect of electrode material on the breakdown voltage of SF₆-N₂ and SF₆-CO₂ mixtures in a weakly non-uniform electric field," *IEEE International Power and Energy Conference (PECon.)*, 2008, pp. 1532–1534.
- [9] W. Opydo and J. Opydo, "Comparative analysis of vacuum and SF₆ as high voltage insulations," *Proc. Int. Conf. on Properties and Applications of Dielectric Materials*, 1992, pp. 396–399.
- [10] Y. Liu *et al*, "Study on Breakdown Probability of Multimaterial Electrodes in EDM," *Adv. Mater. Sci. Eng.*, vol. 2018, pp. 1–8, 2018.
- [11] "AZO Materials," 2019. <https://www.azom.com/> (accessed Jun. 02, 2021).
- [12] N. Barrett *et al*, "Microscopic work function anisotropy and surface chemistry of 316L stainless steel using photoelectron emission microscopy," *J. Electron Spectros. Relat. Phenomena*, vol. 195, pp. 117–124, 2014.
- [13] E. Mitchell and J. Mitchell, "The work functions of copper, silver and aluminium," *Proc. R. Soc. London. Ser. A. Math. Phys. Sci.*, vol. 210, no. 1100, pp. 70–84, 1951.
- [14] High-voltage test techniques - Part 1: General definitions and test requirements, BS EN 60060-1:2010.